

AGENDA

Hartsville-Trousdale Water & Sewer Utility District of
Hartsville/Trousdale County, Tennessee

DATE AND TIME

February 25, 2020 at 5:00 pm

PLACE OF MEETING

County Administration Building
Mayor's Office
328 Broadway
Hartsville, TN

ORDER OF BUSINESS

1. Roll call and determination of quorum.
2. Approval of January 2020 minutes.
3. Approval of January 2020 Financial reports.
4. Water Loss Report.
5. Engineering Report Evan White Mid-Tenn. Engineering
6. General Manager Report:
 - Discussion concerning Fire Sprinkler Policy Customer Charges
 - Approval 2020-2021 Budget
7. Public Comments
8. Board Members Comments
9. Adjournment

January 28, 2020
Hartsville-Trousdale County
Water & Sewer Utility District
Meeting of Board of Commissioners

The meeting of the Hartsville-Trousdale County Water & Sewer Utility District Board of Commissioners was held Tuesday Jan 28, 2020 at 5:00pm in the County Administration Building.

Board members present were Mark Beeler, Stephen Chambers, Craig Moreland, Mark White and Dwight Jewell. Others present were Evan White, Mid Tenn. Engineering, Clint Satterfield, Director of Trousdale County Schools, Tommy McFarland, and Mary Dale Welch.

The meeting was called to order by Chairman Mark Beeler.

The minutes of the December meeting were approved on a motion made by Craig Moreland and seconded by Mark White.

The financial reports for December were reviewed and approved on a motion made by Craig Moreland and seconded by Dwight Jewell.

A discussion was held concerning a complaint that notices are not sent out prior to water being disconnected for non- payment. Tommy advised the Board that if customers register for the on-line bill pay, they will receive notices when the bill is due. An update scheduled for the software may include a notice prior to shut off. This will be looked into.

Evan White reported that the facility plans for the storage tank are under way.
The CDBG project is in the environmental phase, once that is done it can go out for bid.

Next on the agenda was the emergency purchase of a generator for the sewer plant. The one at the plant failed and the cost to repair it was around \$32,000.00. The price for a new replacement generator is \$46,600.00 and has a one-year warranty. Approval was obtained from the executive committee to purchase the new generator. The quote from Sourcewell was \$52,000 and the price from Nixon Power was \$46,600.00. A request was made to obtain the cost of getting an extended warranty on the generator. Dwight Jewell made a motion to concur with the executive committee approval for the purchase at \$46,600. Craig Moreland seconded the motion. The motion was passed.

Clint Satterfield, Director of Schools, ask for a clarification on the sprinkler policy. Letters have been sent to business that are on fire lines requesting information concerning the fire protection infrastructure that they have.

The meeting was adjourned.

Hartsville Trousdale Water and Sewer
Budget To Actual: 2019 - 2020
for Accounting Period 01/31/2020

Account Number	Account Description	Budget	12 Month Ave.	Budget Period	YTD Actual	Variance
204-43190	OTHER GEN SERV- SEWER/CON	\$ 715,028.51	\$ 59,585.71	\$ 417,099.96	\$ 572,237.64	\$ (155,137.68)
204-43191	WATER SALES	\$ 1,979,845.13	\$ 164,987.09	\$ 1,154,909.66	\$ 1,337,075.37	\$ (182,165.71)
204-43193	WATER TAP SALES	\$ 161,472.03	\$ 13,456.00	\$ 94,192.02	\$ 88,050.00	\$ 6,142.02
204-43194	SERVICE CHARGES	\$ 66,005.50	\$ 5,500.46	\$ 38,503.21	\$ 97,467.69	\$ (58,964.48)
204-44110	INVESTMENT INCOME	\$ 25,659.51	\$ 2,138.29	\$ 14,968.05	\$ 20,404.41	\$ (5,436.36)
204-44120	LEASE/RENTALS - CITY	\$ 7,200.00	\$ 600.00	\$ 4,200.00	\$ 3,600.00	\$ 600.00
204-49700	INSURANCE RECOVERY	\$ -	\$ -	\$ -	\$ -	\$ -
204-47590	OTHER FED THRU STATE(GRANT - SEWER	\$ -	\$ -	\$ -	\$ 244,392.12	\$ (244,392.12)
Revenue Total	With Grants	\$ 2,955,210.68	\$ 246,267.56	\$ 1,723,872.90	\$ 2,363,227.23	\$ (639,354.33)
Revenue Total	Without Grants	\$ 2,955,210.68	\$ 246,267.56	\$ 1,723,872.90	\$ 2,118,835.11	\$ (395,562.21)
Expense Total		\$ 2,806,382.39	\$ 233,865.20	\$ 1,637,056.39	\$ 1,701,431.64	\$ (64,375.25)
Total Public Utilities		\$ 148,828.29	\$ 12,402.36	\$ 86,816.50	\$ 661,795.59	\$ (574,979.09)

38.90%

24.53%

Hartsville Trousdale Water and Sewer
Balance Sheet: 2019 - 2020
For the Period Ending 1/31/2020

PUBLIC UTILITIES				
Account Number	Account Description	Debit	Credit	
Assets				
204-11120-000-0	CASH ON HAND	\$400.00	\$0.00	
204-11130-000-0	CASH WBT550167	\$117,788.72	\$0.00	
204-11130-000-1	CB CD MATURITY 12/18/2021 2.1877%	\$1,000,000.00	\$0.00	
204-11130-000-2	WBT CD MATURITY APRIL 6 2020 INT 2.66%	\$457,095.21	\$0.00	
204-11130-000-3	CB CD MATURITY 08/06/2023 INT 2.725%	\$537,484.73	\$0.00	
204-11130-000-4	PAYROLL ACCT	\$10,000.00	\$0.00	
204-11130-000-5	MONEY MARKET ACCOUNT	\$1,749,868.36	\$0.00	
204-11170-000-0	VOUCHERS	\$55.60	\$0.00	
204-11410-000-0	ACCOUNT RECEIVABLE CUSTOMER	\$321,441.60	\$0.00	
204-11600-000-0	PREPAID ITEMS	\$33,209.00	\$0.00	
204-12250-000-0	NET PENSION ASSET	\$28,370.00	\$0.00	
204-13200-000-0	LAND	\$408,043.39	\$0.00	
204-13300-000-0	BUILDINGS & IMPROVEMENTS	\$26,000.00	\$0.00	
204-13310-000-0	ACCUMULATED DEPR - BLDGS &	\$0.00	\$10,081.25	
204-13400-000-0	INFRASTRUCTURE	\$28,325,914.63	\$0.00	
204-13410-000-0	ACCUMULATED DEPR -INFRASTR	\$0.00	\$10,270,990.86	
204-13700-000-0	MACHINERY AND EQUIPMENT	\$1,375,209.34	\$0.00	
204-13800-000-0	CONSTRUCTION IN PROGRESS	\$136,939.18	\$0.00	
204-13800-000-1	CIP HONEYSUCKLE &141	\$82,904.96	\$0.00	
204-13800-000-3	PLANTERS STREET SEWER PROJECT	\$6,130.00	\$0.00	
204-13910-000-0	ALLOWANCE FOR DEPRECIATION	\$0.00	\$1,036,748.29	
204-15400-000-0	PENSION CHANGES IN EXPERIENC	\$56,420.00	\$0.00	
204-15401-000-0	PENSION CHANGES IN ASSUMPTIN	\$20,646.00	\$0.00	
204-15404-000-0	PENSION CHANGES AFTER MEAS	\$32,843.00	\$0.00	
Total Assets		\$34,726,763.72	\$11,317,820.40	\$23,408,943.32
Liabilities				
204-21100-000-0	ACCOUNTS PAYABLE	\$0.00	\$94,048.74	
204-21200-000-0	ACCRUED WAGES	\$0.00	\$19,141.28	
204-21330-000-0	RETIREMENT CONTRIBUTIONS	\$0.00	\$0.52	
204-21342-000-0	HEALTH INSURANCE	\$0.64	\$0.00	
204-21343-000-0	AMERICAN GENERAL	\$0.00	\$177.85	
204-21344-000-0	DENTAL INS	\$41.46	\$0.00	
204-21345-000-0	AFLAC	\$0.00	\$38.64	
204-21346-000-0	OTHER PR DED	\$0.00	\$75.26	
204-21347-000-0	AMERICAN FIDELITY	\$72.24	\$0.00	
204-21348-000-0	VISION	\$15.10	\$0.00	
204-21395-000-0	ACCRUED LEAVE - CURRENT	\$0.00	\$27,822.12	
204-21500-000-0	DUE TO SOLID WASTE	\$0.00	\$913.64	
204-21530-000-0	DUE TO STATE OF TN SALES T	\$0.00	\$15,745.00	
204-21900-000-1	LEAK PROTECTION	\$56.00	\$0.00	
204-21900-000-2	LINE PROTECTION	\$18.50	\$0.00	
204-21951-000-0	CUSTOMER DEPOSIT	\$0.00	\$4,000.00	
204-27200-000-2	REVENUE BNONDS PAYABLE LONG-2	\$0.00	\$3,411,591.12	
204-27200-000-3	REVENUE BNONDS PAYABLE LONG-3	\$0.00	\$1,788,669.09	
204-29980-000-0	PENSION CHANGES IN EXPERIE	\$0.00	\$47,689.00	
204-29982-000-0	PENSION CHANGES IN EXPERIENC	\$0.00	\$6,464.00	
Total Liabilities		\$203.94	\$5,416,376.26	\$5,416,172.32
Equities				
204-39900-000-0	FUND BALANCE	\$0.00	\$17,330,975.41	\$17,330,975.41
Total Equity				
Revenues Less Expenditures			\$661,795.59	\$661,795.59
Total Equity				\$17,992,771.00
Total Liabilities and Equity				\$23,408,943.32
Total	PUBLIC UTILITIES	\$34,726,967.66	\$34,726,967.66	

**Hartsville Trousdale Water and Sewer
Income Statement: 2019 - 2020
For the Period Ending 01/31/2020**

PUBLIC UTILITIES

Revenues

Account Number	Account Descriptionr	Estimated Revenue	Activity this Period	Revenue YTD
204-43190-000-1	OTHER GEN SERV- SEWER/CON	\$715,028.51	\$83,485.06	\$572,237.64
204-43191-000-1	WATER SALES	\$1,979,845.13	\$188,242.38	\$1,337,075.37
204-43193-000-1	TAP SALES	\$161,472.03	\$0.00	\$88,050.00
204-43194-000-1	SERVICE CHARGES	\$66,005.50	\$16,286.38	\$97,467.69
204-44110-000-1	INVESTMENT INCOME	\$25,659.51	\$2,032.56	\$20,404.41
204-44120-000-1	LEASE/RENTALS	\$7,200.00	\$600.00	\$3,600.00
204-47590-000-2	OTHER FED THRU STATE(GRANT - SEWER	\$0.00	\$0.00	\$244,392.12
Total Fund	PUBLIC UTILITIES	\$2,955,210.68	\$290,646.38	\$2,363,227.23

Expenditures

Account Number	Account Descriptionr	Approp Amount	Activity this Period	Expenditure YTD
204-55900-105-1	EMPLOYEE WAGES-SUPERVISOR/ - CITY	\$72,713.06	\$6,432.62	\$42,126.66
204-55900-162-1	EMPLOYEE WAGES-CLERICAL PE - CITY	\$130,247.21	\$14,361.22	\$71,781.65
204-55900-187-1	EMPLOYEE WAGES-OVERTIME PA - CITY	\$43,762.88	\$9,515.31	\$54,162.84
204-55900-188-1	EMPLOYEE WAGES-BONUS PAYME - CITY	\$12,650.01	\$0.00	\$13,100.00
204-55900-189-1	EMPLOYEE WAGES-OTHER SALAR - CITY	\$472,378.81	\$38,358.78	\$274,235.74
204-55900-191-1	BOARD AND COMMITTEE MEMBER - CITY	\$1,425.00	\$200.00	\$1,550.00
204-55900-196-1	IN-SERVICE TRAINING - CITY	\$5,000.00	\$0.00	\$4,590.00
204-55900-201-1	EMPLOYEE BENEFIT SOCIAL SE - CITY	\$55,500.00	\$5,016.73	\$33,564.01
204-55900-204-1	EMPLOYEE BENEFIT STATE RET - CITY	\$36,500.00	\$3,465.24	\$20,574.06
204-55900-207-1	EMPLOYEE BENEFIT MEDICAL I - CITY	\$69,480.00	\$5,464.00	\$38,406.58
204-55900-301-1	ACCOUNTING SERVICES	\$4,070.00	\$0.00	\$0.00
204-55900-307-1	COMMUNICATION - CITY	\$45,729.00	\$939.04	\$13,843.00
204-55900-317-1	DATA PROCESSING - CITY	\$23,727.52	\$718.75	\$6,783.00
204-55900-320-1	DUES AND MEMBERSHIPS - CITY	\$3,830.99	\$224.00	\$2,654.80
204-55900-321-1	ENGINEERING SERVICES	\$10,000.00	\$0.00	\$0.00
204-55900-332-1	LEGAL NOTICES, RECORDING A - CITY	\$6,000.00	\$0.00	\$39.00
204-55900-335-1	MAINTENANCE REPAIR BUILDIN - CITY	\$2,900.00	\$0.00	\$0.00
204-55900-336-1	MAINTENANCE REPAIR EQUIPME - CITY	\$159,890.00	\$6,956.00	\$69,626.34
204-55900-337-1	MAINTENACERPAIR OFFICE EQ - CITY	\$717.00	\$0.00	\$62.95
204-55900-338-1	MAINTENANCE REPAIR VEHICL - CITY	\$30,000.00	\$612.07	\$6,231.00
204-55900-348-1	POSTAL CHARGES - CITY	\$18,000.00	\$5,568.00	\$11,696.39
204-55900-355-1	TRAVEL - CITY	\$1,603.00	\$0.00	\$237.00
204-55900-359-2	DISPOSAL FEES	\$6,500.00	\$950.16	\$3,260.60
204-55900-361-1	PERMITS - CITY	\$10,789.91	\$4,840.00	\$11,456.30
204-55900-399-1	OTHER CONTRACTED SERVICES - CITY	\$13,596.75	\$0.00	\$7,914.84
204-55900-415-1	ELECTRICITY - CITY	\$287,921.67	\$24,396.84	\$165,157.14
204-55900-425-1	GASOLINE - CITY	\$27,178.83	\$0.00	\$15,048.14
204-55900-434-1	NATURAL GAS - CITY	\$7,332.00	\$1,427.38	\$3,485.75
204-55900-435-1	OFFICE SUPPLIES - CITY	\$5,752.49	\$165.24	\$3,581.29
204-55900-450-1	TIRES AND TUBES - CITY	\$5,562.25	\$0.00	\$4,988.69
204-55900-463-1	TESTING (WATER SAMPLES ETC - CITY	\$30,000.00	\$1,180.00	\$14,501.68
204-55900-468-1	CHEMICALS - CITY	\$145,337.00	\$14,130.88	\$103,587.38
204-55900-499-1	OTHER SUPPLIES AND MATERIA - CITY	\$215,000.00	\$25,278.40	\$173,270.67
204-55900-506-1	LIABILITY INSURANCE - CITY	\$95,991.00	\$6,642.00	\$44,899.00
204-55900-514-1	DEPRECIATION - CITY	\$585,232.01	\$58,500.00	\$402,000.00
204-55900-599-1	OTHER CHARGES - CITY	\$50,000.00	\$1,393.72	\$21,855.52
204-55900-603-1	INTEREST ON LOAN - CITY	\$106,081.00	\$8,698.00	\$61,159.62
204-55900-719-1	OFFICE EQUIPMENT - CITY	\$7,983.00	\$0.00	\$0.00
Total Fund	PUBLIC UTILITIES	\$2,806,382.39	\$245,434.38	\$1,701,431.64

Fund Balance		\$17,330,975.41
Total Revenues	\$290,646.38	\$2,363,227.23
Less Total Expenditures	\$245,434.38	\$1,701,431.64
Net Income	\$45,212.00	\$661,795.59
New Fund Balance		\$17,992,771.00

Hartsville Trousdale Water and Sewer

Revenue Statement: 2019 - 2020
for Accounting Period 1/31/2020

PUBLIC UTILITIES

Account #	Account Description	Estimated Revenue	Activity this Period	Revenue YTD	Uncollected YTD	% Coll
204-43190	OTHER GEN SERV- SEWER/CON	\$ 715,028.51	\$ 83,485.06	\$ 572,237.64	\$ 142,790.87	80.03%
204-43191	WATER SALES	\$ 1,979,845.13	\$ 188,242.38	\$ 1,337,075.37	\$ 642,769.76	67.53%
204-43193	TAP SALES	\$ 161,472.03	\$ -	\$ 88,050.00	\$ 73,422.03	54.53%
204-43194	SERVICE CHARGES	\$ 66,005.50	\$ 16,286.38	\$ 97,467.69	\$ (31,462.19)	147.67%
204-44110	INVESTMENT INCOME	\$ 25,659.51	\$ 2,032.56	\$ 20,404.41	\$ 5,255.10	79.52%
204-44120	LEASE/RENTALS	\$ 7,200.00	\$ 600.00	\$ 3,600.00	\$ 3,600.00	50.00%
204-47590	OTHER FED THRU STATE(GRANT)	\$ -	\$ -	\$ 244,392.12	\$ (244,392.12)	0.00%
Total Revenue: PUBLIC UTILITIES		\$ 2,955,210.68	\$ 290,646.38	\$ 2,363,227.23	\$ 591,983.45	79.97%

Hartsville Trousdale Water and Sewer
Income Statement: 2019 - 2020
For the Period Ending 01/31/2020

Expenditures

Account #	Account Description	Approp Amount	Activity this Period	Expenditure YTD	Encumbrance YTD	Unencumbered Balance	% Exp. & Enc.
204-55900-105-1	EMPLOYEE WAGES-SUPERVISOR/ - CITY	\$72,713.06	\$6,432.62	\$42,126.66	\$0.00	\$30,586.40	57.94%
204-55900-162-1	EMPLOYEE WAGES-CLERICAL PE - CITY	\$130,247.21	\$14,361.22	\$71,781.65	\$0.00	\$58,465.56	55.11%
204-55900-187-1	EMPLOYEE WAGES-OVERTIME PA - CITY	\$43,762.88	\$9,515.31	\$54,162.84	\$0.00	(\$10,399.96)	123.76%
204-55900-188-1	EMPLOYEE WAGES-BONUS PAYME - CITY	\$12,650.01	\$0.00	\$13,100.00	\$0.00	(\$449.99)	103.56%
204-55900-189-1	EMPLOYEE WAGES-OTHER SALAR - CITY	\$472,378.81	\$38,358.78	\$274,235.74	\$0.00	\$198,143.07	58.05%
204-55900-191-1	BOARD AND COMMITTEE MEMBER - CITY	\$1,425.00	\$200.00	\$1,550.00	\$0.00	(\$125.00)	108.77%
204-55900-196-1	IN-SERVICE TRAINING - CITY	\$5,000.00	\$0.00	\$4,590.00	\$0.00	\$410.00	91.80%
204-55900-201-1	EMPLOYEE BENEFIT SOCIAL SE - CITY	\$55,500.00	\$5,016.73	\$33,564.01	\$0.00	\$21,935.99	60.48%
204-55900-204-1	EMPLOYEE BENEFIT STATE RET - CITY	\$36,500.00	\$3,465.24	\$20,574.06	\$0.00	\$15,925.94	56.37%
204-55900-207-1	EMPLOYEE BENEFIT MEDICAL I - CITY	\$69,480.00	\$5,464.00	\$38,406.58	\$0.00	\$31,073.42	55.28%
204-55900-301-1	ACCOUNTING SERVICES	\$4,070.00	\$0.00	\$0.00	\$0.00	\$4,070.00	0.00%
204-55900-307-1	COMMUNICATION - CITY	\$45,729.00	\$939.04	\$13,843.00	\$2,098.24	\$29,787.76	30.27%
204-55900-317-1	DATA PROCESSING - CITY	\$23,727.52	\$718.75	\$6,783.00	\$2,000.00	\$14,944.52	28.59%
204-55900-320-1	DUES AND MEMBERSHIPS - CITY	\$3,830.99	\$224.00	\$2,654.80	\$0.00	\$1,176.19	69.30%
204-55900-321-1	ENGINEERING SERVICES	\$10,000.00	\$0.00	\$0.00	\$0.00	\$10,000.00	0.00%
204-55900-332-1	LEGAL NOTICES, RECORDING A - CITY	\$6,000.00	\$0.00	\$39.00	\$0.00	\$5,961.00	0.65%
204-55900-335-1	MAINTENANCE REPAIR BUILDIN - CITY	\$2,900.00	\$0.00	\$0.00	\$0.00	\$2,900.00	0.00%
204-55900-336-1	MAINTENANCE REPAIR EQUIPME - CITY	\$159,890.00	\$6,956.00	\$69,626.34	\$6,293.23	\$83,970.43	43.55%
204-55900-337-1	MAINTENACERPAIR OFFICE EQ - CITY	\$717.00	\$0.00	\$62.95	\$0.00	\$654.05	8.78%
204-55900-338-1	MAINTENANCE REPAIR VEHICL - CITY	\$30,000.00	\$612.07	\$6,231.00	\$0.00	\$23,769.00	20.77%
204-55900-348-1	POSTAL CHARGES - CITY	\$18,000.00	\$5,568.00	\$11,696.39	\$0.00	\$6,303.61	64.98%
204-55900-355-1	TRAVEL - CITY	\$1,603.00	\$0.00	\$237.00	\$0.00	\$1,366.00	14.78%
204-55900-359-2	DISPOSAL FEES	\$6,500.00	\$950.16	\$3,260.60	\$0.00	\$3,239.40	50.16%
204-55900-361-1	PERMITS - CITY	\$10,789.91	\$4,840.00	\$11,456.30	\$0.00	(\$666.39)	106.18%
204-55900-399-1	OTHER CONTRACTED SERVICES - CITY	\$13,596.75	\$0.00	\$7,914.84	\$0.00	\$5,681.91	58.21%
204-55900-415-1	ELECTRICITY - CITY	\$287,921.67	\$24,396.84	\$165,157.14	\$0.00	\$122,764.53	57.36%
204-55900-425-1	GASOLINE - CITY	\$27,178.83	\$0.00	\$15,048.14	\$0.00	\$12,130.69	55.37%
204-55900-434-1	NATURAL GAS - CITY	\$7,332.00	\$1,427.38	\$3,485.75	\$0.00	\$3,846.25	47.54%
204-55900-435-1	OFFICE SUPPLIES - CITY	\$5,752.49	\$165.24	\$3,581.29	\$538.71	\$1,632.49	62.26%
204-55900-450-1	TIRES AND TUBES - CITY	\$5,562.25	\$0.00	\$4,988.69	\$0.00	\$573.56	89.69%
204-55900-463-1	TESTING (WATER SAMPLES ETC - CITY	\$30,000.00	\$1,180.00	\$14,501.68	\$0.00	\$15,498.32	48.34%
204-55900-468-1	CHEMICALS - CITY	\$145,337.00	\$14,130.88	\$103,587.38	(\$3,721.50)	\$45,471.12	71.27%
204-55900-499-1	OTHER SUPPLIES AND MATERIA - CITY	\$215,000.00	\$25,278.40	\$173,270.67	\$952.54	\$40,776.79	80.59%
204-55900-506-1	LIABILITY INSURANCE - CITY	\$95,991.00	\$6,642.00	\$44,899.00	\$0.00	\$51,092.00	46.77%
204-55900-514-1	DEPRECIATION - CITY	\$585,232.01	\$58,500.00	\$402,000.00	\$0.00	\$183,232.01	68.69%
204-55900-599-1	OTHER CHARGES - CITY	\$50,000.00	\$1,393.72	\$21,855.52	\$17,807.75	\$10,336.73	43.71%
204-55900-603-1	INTEREST ON LOAN - CITY	\$106,081.00	\$8,698.00	\$61,159.62	\$0.00	\$44,921.38	57.65%
204-55900-719-1	OFFICE EQUIPMENT - CITY	\$7,983.00	\$0.00	\$0.00	\$0.00	\$7,983.00	0.00%
Total Fund	PUBLIC UTILITIES	\$2,806,382.39	\$245,434.38	\$1,701,431.64	\$25,968.97	\$1,078,981.78	60.63%

WATER LOSS WORKSHEET

	2019												2020													
	JULY	AUG	SEP	OCT	NOV	DEC	JAN	FEB	MAR	APR	MAY	JUN	TOTAL	JULY	AUG	SEP	OCT	NOV	DEC	JAN	FEB	MAR	APR	MAY	JUN	TOTAL
WATER PUMPED	38.588	36.016	36.566	36.400	36.572	35.358	35.249						254.7													254.7
WATER SOLD	17.131	19.685	23.289	17.158	19.025	16.235	18.483						131.0													131.0
WHOLESALE	2.952	3.211	3.866	3.979	3.966	3.415	3.963						25.4													25.4
TOTAL WATER SOLD	20.083	22.896	27.156	21.138	22.991	19.651	22.447						156.4													156.4
METER IN HOUSE	0.387	0.318	0.317	0.358	0.488	0.564	0.370						2.8													2.8
FIRE DEPART	0.006	0.010	0.000	0.000	0.000	0.000	0.000						0.0													0.0
FLUSHING	0.159	0.169	0.185	0.181	0.108	0.067	0.000						0.9													0.9
BILL ADJ	0.000	0.000	0.000	0.000	0.000	0.000	0.000						0.0													0.0
TOTAL ACCOUNTED FOR WATER	20.635	23.393	27.658	21.677	23.588	20.282	22.817						160.0													160.0
TOTAL UNACCOUNTED FOR WATER	17.953	12.623	8.908	14.723	12.985	15.077	12.432						94.7													94.7
% UNACCOUNTED FOR WATER LOSS 2018-19	46.5%	35.0%	24.4%	40.4%	35.5%	42.6%	35.3%						37.1%													37.1%
% UNACCOUNTED FOR WATER LOSS 2017-18	23.5%	26.5%	26.7%	40.6%	28.9%	29.3%	29.0%						33.2%													33.2%

	48.0%	36.4%	25.7%	41.9%	37.1%	44.4%	36.3%	#DIV/0!	#DIV/0!	#DIV/0!	#DIV/0!	#DIV/0!	25.4%
WATER PUMPED VS TOTAL WATER SOLD													

ELECTRICITY	\$ 14,311.71	\$ 13,762.45	\$ 12,084.94	\$ 12,568.45	\$11,578.07	\$ 11,755.97	\$ 13,038.61						\$ 89,100.20
CHEMICALS	\$ 10,854.05	\$ 11,835.90	\$ 7,585.20	\$ 11,262.46	\$4,922.70	\$ 12,974.86	\$ 8,889.36						\$ 68,274.53

WATER SALES	\$ 194,262.66	\$ 211,415.68	\$ 234,101.87	\$ 188,872.02	\$ 194,822.11	\$ 174,373.39	\$ 188,781.25						\$ 1,386,628.98
SEWER SALES	\$ 74,263.99	\$ 81,837.04	\$ 93,654.63	\$ 69,787.06	\$ 80,288.49	\$ 75,113.64	\$ 81,119.72						\$ 556,064.57
TOTAL SALES	\$ 268,526.65	\$ 293,252.72	\$ 327,756.50	\$ 258,659.08	\$ 275,110.60	\$ 249,487.03	\$ 269,900.97	\$ -	\$ -	\$ -	\$ -	\$ -	\$ 1,942,693.55

WATER SOLD	20.0830	22.8960	27.1556	21.1375	22.9909	19.6508	22.4466						156.3605
WATER SOLD TOTAL	20.0830	22.8960	27.1556	21.1375	22.9909	19.6508	22.4466	0.0000	0.0000	0.0000	0.0000	0.0000	156.3605

WATER PUMPED	38.915	36.321	36.876	36.708	36.882	35.658	35.548	0.000	0.000	0.000	0.000	0.000	316.430
	0.327	0.305	0.310	0.308	0.310	0.300	0.299	0.302	0.198	0.000	0.000	0.000	2.658
	38.588	36.016	36.566	36.400	36.572	35.358	35.249	35.657	23.365	0.000	0.000	0.000	313.772

0.84%

Hartsville Trousdale Water & Sewer Utility Department Rules and Regulations

22. Fire Sprinkler Systems

1. All customer fire sprinkler system connections (including private fire hydrants) must be approved by of HTWSUD.
2. Customers are not permitted to use water provided for a fire sprinkler system for any purpose other than fire protection. When a customer uses water from a fire sprinkler system for any purpose other than fire protection, the customer must pay for water used as estimated by HTWSUD in accordance with its rates and fees for water service.
3. No cross-connection is allowed between a customer's fire sprinkler system and its domestic, potable water lines.
4. HTWSUD shall have right of access during business hours to a customer's premises for the purpose of inspecting the customer's fire sprinkler system to ensure the fire sprinkler system meets HTWSUD's rules and regulations and poses no threat to the integrity of the HTWSUD public water system.
5. Fire sprinkler systems shall be installed, owned and maintained by the customer. Other than the enforcement of its own regulations governing fire sprinkler systems, HTWSUD assumes no responsibility for seeing that the customer's installation and maintenance of its fire sprinkler system complies with any applicable codes, regulations or standards governing fire sprinkler systems.
6. Multiple connections for fire sprinkler service to one structure or building that is in service at the effective date of this regulation shall, for billing purposes only, be considered a single connection.
7. HTWSUD does not guarantee any pressure or flow minimums for fire sprinkler system connections.
8. When a customer discovers a leak in its fire sprinkler system, the leak must be repaired as soon as possible.
9. When HTWSUD discovers a leak in a customer's fire sprinkler system, the customer must repair the leak within 72 hours of notice by HTWSUD. If the customer does not repair the leak within 72 hours, the customer will pay a penalty of \$100.00 per day until the leak is repaired and will pay for water lost after 72 hours due to the leak as estimated by HTWSUD until the leak is repaired in accordance with its rates and fees for water service.

Hartsville Trousdale Water & Sewer Utility Department Rules and Regulations

Fire Sprinkler System Rates and Fees

Fire Line Taps will be billed the following each month:

Monthly base charge based upon the number of minimum bills per size tap as specified below

Private Fire Hydrants @ \$15.00 each per month

Sprinkler Heads @ \$.15 each per month

Fireline Pipe Size	Monthly Base Charge
2-inch	2 Minimum Bills
4-inch	4 Minimum Bills
6-inch	6 Minimum Bills
8-inch	8 Minimum Bills

When a customer is required to pay for water provided by a fire sprinkler system, water must be paid for at the prevailing rates approved by HTWSUD.

Adoption Date: December 17, 2019

Effective Date: January 1, 2020

Customers City

Main Size Inches	# Heads	# Fire Hydrants
\$ 16.63	\$ 0.15	\$ 15.00

Monthly	Yearly
---------	--------

Foodland	6	100	0	\$ 114.78	\$ 1,377.36
Dollar General/Subway (24 Heads)	6	126	0	\$ 118.68	\$ 1,424.16
Trousdale Senior Living Center	8	305	1	\$ 193.79	\$ 2,325.48
Mueller Brass	8	100	1	\$ 163.04	\$ 1,956.48
	6	100	1	\$ 129.78	\$ 1,557.36
Trousdale County High School	6	580	1	\$ 201.78	\$ 2,421.36
	6	325	1	\$ 163.53	\$ 1,962.36
Trousdale County Elementary School	6	24	1	\$ 118.38	\$ 1,420.56
	6	3.60	15.00	\$ 5,804.28	

Customers Rural

Main Size Inches	# Heads	# Fire Hydrants
\$ 27.94	\$ 0.15	\$ 15.00

Monthly	Yearly
---------	--------

ARC	8	69	3	\$ 278.87	\$ 3,346.44
V&C	8	100	2	\$ 268.52	\$ 3,222.24
	6	100	1	\$ 197.64	\$ 2,371.68
	6	15.00	15.00	\$ 5,593.92	

Hartsville Trousdale Water and Sewer Utility Department
Proposed 2020-2021 Budget

Account Number	Account Description	2018 - 2019 Budget	2019 - 2020 Budget	2019 - 2020 Estimated	1.25%	1.25%
					2020 - 2021 Proposed Budget with Grant/Loan	2020 - 2021 Proposed Budget without Grant/Loan
204-43190	OTHER GEN SERV- SEWER/CON	\$ 701,606.00	\$ 715,028.51	\$980,978.81	\$980,978.81	\$980,978.81
204-43191	WATER SALES	\$ 1,962,203.00	\$ 1,979,845.13	\$2,292,129.21	\$2,320,780.82	\$2,320,780.82
204-43193	WATER TAP SALES	\$ 123,750.00	\$ 161,472.03	\$150,942.86	\$152,829.64	\$152,829.64
204-43194	SERVICE CHARGES	\$ 36,785.00	\$ 66,005.51	\$167,087.47	\$169,176.06	\$169,176.06
204-44110	INVESTMENT INCOME	\$ 8,490.00	\$ 25,659.51	\$34,978.99	\$35,416.23	\$35,416.23
204-44120	LEASE/RENTALS - CITY	\$ -	\$ 7,200.00	\$7,200.00	\$7,200.00	\$7,200.00
204-47590	OTHER FED THRU STATE(GRANT)	\$ -	\$ -	\$244,392.12	\$617,849.00	\$0.00
204-49700	INSURANCE RECOVERY	\$ -	\$ -	\$ -	\$0.00	\$0.00
Revenue Total		\$ 2,832,834.00	\$ 2,955,210.68	\$3,877,709.45	\$ 4,284,230.56	\$ 3,666,381.56
204-55900-105	EMPLOYEE WAGES-SUPERVISOR	\$ 69,713.00	\$ 72,713.06	\$ 72,217.13	\$ 74,898.30	\$ 74,898.30
204-55900-162	EMPLOYEE WAGES-CLERICAL PE	\$ 100,016.00	\$ 130,247.21	\$ 123,054.26	\$ 144,526.30	\$ 144,526.30
204-55900-187	EMPLOYEE WAGES-OVERTIME PA	\$ 68,605.00	\$ 43,762.88	\$ 92,850.58	\$ 86,532.84	\$ 86,532.84
204-55900-188	EMPLOYEE WAGES-BONUS PAYME	\$ 5,445.00	\$ 12,650.01	\$ 22,457.14	\$ 14,450.00	\$ 14,450.00
204-55900-189	EMPLOYEE WAGES-OTHER SALAR	\$ 449,749.00	\$ 472,378.81	\$ 470,118.41	\$ 558,847.12	\$ 558,847.12
204-55900-191	BOARD AND COMMITTEE MEMBER	\$ 2,200.00	\$ 1,425.00	\$ 2,657.14	\$ 2,736.86	\$ 2,736.86
204-55900-196	IN-SERVICE TRAINING	\$ 3,714.00	\$ 5,000.00	\$ 7,868.57	\$ 8,104.63	\$ 8,104.63
204-55900-201	EMPLOYEE BENEFIT SOCIAL SE	\$ 53,872.00	\$ 55,500.00	\$ 57,538.30	\$ 60,536.32	\$ 60,536.32
204-55900-204	EMPLOYEE BENEFIT STATE RET	\$ 34,894.00	\$ 36,500.00	\$ 35,269.82	\$ 43,240.23	\$ 43,240.23
204-55900-207	EMPLOYEE BENEFIT MEDICAL I	\$ 63,624.00	\$ 69,480.00	\$ 65,839.85	\$ 80,976.00	\$ 80,976.00
204-55900-295	LANDFILL SERVICES - SEWER	\$ 6,551.00	\$ -	\$ -	\$ -	\$ -
204-55900-301	ACCOUNTING SERVICES	\$ 4,070.00	\$ 4,070.00	\$ 4,070.00	\$ 4,192.10	\$ 4,192.10
204-55900-307	COMMUNICATION	\$ 45,729.00	\$ 45,729.00	\$ 23,730.86	\$ 24,442.78	\$ 24,442.78
204-55900-317	DATA PROCESSING	\$ 25,782.00	\$ 23,727.52	\$ 22,000.00	\$ 55,000.00	\$ 55,000.00
204-55900-320	DUES AND MEMBERSHIPS	\$ 3,831.00	\$ 3,830.99	\$ 4,551.09	\$ 4,687.62	\$ 4,687.62
204-55900-321	ENGINEERING SERVICES	\$ 2,500.00	\$ 10,000.00	\$ 10,000.00	\$ 10,300.00	\$ 10,300.00
204-55900-332	LEGAL NOTICES, RECORDING A	\$ 19,654.00	\$ 6,000.00	\$ 66.86	\$ 68.86	\$ 68.86
204-55900-335	MAINTENANCE REPAIR BUILDIN	\$ 2,900.00	\$ 2,900.00	\$ 2,900.00	\$ 2,987.00	\$ 2,987.00
204-55900-336	MAINTENANCE REPAIR EQUIPME	\$ 159,890.00	\$ 159,890.00	\$ 119,359.44	\$ 159,890.00	\$ 159,890.00
204-55900-337	MAINTENACERPAIR OFFICE EQ	\$ 717.00	\$ 717.00	\$ 107.91	\$ 111.15	\$ 111.15
204-55900-338	MAINTENANCE REPAIR VEHICL	\$ 42,904.00	\$ 30,000.00	\$ 10,681.71	\$ 11,002.17	\$ 11,002.17
204-55900-348	POSTAL CHARGES	\$ 15,061.00	\$ 18,000.00	\$ 20,050.95	\$ 20,652.48	\$ 20,652.48
204-55900-355	TRAVEL	\$ 1,603.00	\$ 1,603.00	\$ 406.29	\$ 1,500.00	\$ 1,500.00
204-55900-359	DISPOSAL FEES	\$ -	\$ 6,500.00	\$ 5,589.60	\$ 5,757.29	\$ 5,757.29
204-55900-361	PERMITS	\$ 4,000.00	\$ 10,789.91	\$ 19,639.37	\$ 15,000.00	\$ 15,000.00
204-55900-399	OTHER CONTRACTED SERVICES	\$ 4,739.00	\$ 13,596.75	\$ 13,568.30	\$ 13,975.35	\$ 13,975.35
204-55900-415	ELECTRICITY	\$ 247,333.00	\$ 287,921.67	\$ 283,126.53	\$ 291,620.32	\$ 291,620.32
204-55900-425	GASOLINE	\$ 25,625.00	\$ 27,178.83	\$ 25,796.81	\$ 26,570.72	\$ 26,570.72
204-55900-434	NATURAL GAS	\$ 7,332.00	\$ 7,332.00	\$ 5,975.57	\$ 6,154.84	\$ 6,154.84
204-55900-435	OFFICE SUPPLIES	\$ 5,145.00	\$ 5,752.49	\$ 6,139.35	\$ 6,323.53	\$ 6,323.53
204-55900-450	TIRES AND TUBES	\$ -	\$ 5,562.25	\$ 8,552.04	\$ 8,808.60	\$ 8,808.60
204-55900-463	TESTING (WATER SAMPLES ETC	\$ 30,000.00	\$ 30,000.00	\$ 24,860.02	\$ 25,605.82	\$ 25,605.82
204-55900-468	CHEMICALS	\$ 145,337.00	\$ 145,337.00	\$ 177,578.37	\$ 182,905.72	\$ 182,905.72
204-55900-499	OTHER SUPPLIES AND MATERIA	\$ 98,965.00	\$ 215,000.00	\$ 297,035.43	\$ 305,946.50	\$ 305,946.50
204-55900-506	LIABILITY INSURANCE	\$ 95,991.00	\$ 95,991.00	\$ 76,969.71	\$ 79,278.81	\$ 79,278.81
204-55900-514	DEPRECIATION	\$ 585,232.00	\$ 585,232.01	\$ 689,142.86	\$ 819,598.48	\$ 819,598.48
204-55900-599	OTHER CHARGES	\$ 34,880.00	\$ 50,000.00	\$ 37,466.61	\$ 38,590.60	\$ 38,590.60
204-55900-603	INTEREST ON LOAN	\$ 140,000.00	\$ 106,081.00	\$ 104,845.06	\$ 131,080.00	\$ 131,080.00
204-55900-719	OFFICE EQUIPMENT	\$ 6,081.00	\$ 7,983.00	\$ -	\$ 8,000.00	\$ 8,000.00
Expense Total		\$ 2,613,684.00	\$ 2,806,382.39	\$ 2,944,081.95	\$ 3,334,899.34	\$ 3,334,899.34
Total		\$ 219,150.00	\$ 148,828.28	\$ 933,627.50	\$ 949,331.22	\$ 331,482.22
					3%	3%
					22.16%	9.04%
					With	Without
					Grant / Loan	Grant / Loan

**PROJECT COSTS AND PURCHASE REQUEST
2020-2021 BUDGET YEAR**

Item Description	Loans/Project	Cash/Project	Depreciation	Interest Payments	Employees & Benefits
	\$ 5,255,105.00	\$ -	\$ 716,911.85	\$ 102,555.00	\$ 1,000,263.80
2.0 MG Water Tank Project	\$ 1,750,000.00	\$ -	\$ 43,750.00	\$ 28,525.00	
Flex Net CDBG		\$ 588,000.00	\$ 14,700.00	No Payment	
Shop Building		\$ 500,000.00	\$ 12,500.00	No Payment	
Planters Street Sewer Project		\$ 75,001.00	\$ 1,875.03	No Payment	
141 HWY		\$ 264,000.00	\$ 6,600.00	No Payment	
5500 Utility Bed 4X4 Truck (Optional)		\$ 56,422.84	\$ 11,284.57	No Payment	
1500 Silverado 4x4 Truck (Optional)		\$ 29,942.60	\$ 5,988.52	No Payment	
1500 Silverado 4x4 Truck (Optional)		\$ 29,942.60	\$ 5,988.52	No Payment	
25 TON trailer (Optional)		\$ 16,000.00	\$ 3,200.00	No Payment	
2 Employees with Benefits (Optional)					\$ 75,818.32
	\$ 1,750,000.00	\$ 1,427,001.00	\$ 102,686.63	\$ 28,525.00	\$ 75,818.32
Totals	\$ 7,005,105.00	\$ 1,427,001.00	\$ 819,598.48	\$ 131,080.00	\$ 1,076,082.12



Wilson County Motors

Sabrina Edwards | 615-444-9642 | Sabrina@wilsoncountyauto.com

Hartsville/Trousdale County

Vehicle: [Fleet] 2020 Chevrolet Silverado MD (CK56403) 4WD Reg Cab Work Truck





Wilson County Motors

Sabrina Edwards | 615-444-9642 | Sabrina@wilsoncountyauto.com

Wilson County Motors

Prepared By:

Sabrina Edwards
Wilson County Motors
615-444-9642
Sabrina@wilsoncountyauto.com

This document contains information considered Confidential between GM and its Clients uniquely. The information provided is not intended for public disclosure. Prices, specifications, and availability are subject to change without notice, and do not include certain fees, taxes and charges that may be required by law or vary by manufacturer or region. Performance figures are guidelines only, and actual performance may vary. Photos may not represent actual vehicles or exact configurations. Content based on report preparer's input is subject to the accuracy of the input provided.

Data Version: 10374. Data Updated: Feb 20, 2020 10:40:00 PM PST.



Wilson County Motors

Sabrina Edwards | 615-444-9642 | Sabrina@wilsoncountyauto.com

Vehicle: [Fleet] 2020 Chevrolet Silverado MD (CK56403) 4WD Reg Cab Work Truck (✔ Complete)

Price Summary

PRICE SUMMARY

	VQ2	MSRP
Base Price	\$46,705.40	\$51,100.00
Total Options	\$8,095.80	\$3,180.00
Vehicle Subtotal	\$54,801.20	\$54,280.00
Tire Weight Tax (TWT)	\$26.64	\$26.64
Destination Charge	\$1,595.00	\$1,595.00
Grand Total	\$56,422.84	\$55,901.64

This document contains information considered Confidential between GM and its Clients uniquely. The information provided is not intended for public disclosure. Prices, specifications, and availability are subject to change without notice, and do not include certain fees, taxes and charges that may be required by law or vary by manufacturer or region. Performance figures are guidelines only, and actual performance may vary. Photos may not represent actual vehicles or exact configurations. Content based on report preparer's input is subject to the accuracy of the input provided.

Data Version: 10374. Data Updated: Feb 20, 2020 10:40:00 PM PST.



Wilson County Motors

Sabrina Edwards | 615-444-9642 | Sabrina@wilsoncountyauto.com

Vehicle: [Fleet] 2020 Chevrolet Silverado MD (CK56403) 4WD Reg Cab Work Truck (✔ Complete)

Technical Specifications

Medium Duty

Medium Duty Performance

Front Axle %	64.79	Rear Axle %	35.21
Driver Weight	350.0 lbs	Front Ground Load	5744.00 lbs
Rear Ground Load	3121.00 lbs	1st gear High Speed (High Axle Gear)	20.40 MPH
2nd gear High Speed (High Axle Gear)	35.13 MPH	3rd gear High Speed (High Axle Gear)	45.16 MPH
4th gear High Speed (High Axle Gear)	63.23 MPH	5th gear High Speed (High Axle Gear)	90.32 MPH
6th gear High Speed (High Axle Gear)	103.65 MPH	1st gear Low Speed (High Axle Gear)	11.25 MPH
2nd gear Low Speed (High Axle Gear)	19.38 MPH	3rd gear Low Speed (High Axle Gear)	24.92 MPH
4th gear Low Speed (High Axle Gear)	34.88 MPH	5th gear Low Speed (High Axle Gear)	49.83 MPH
6th gear Low Speed (High Axle Gear)	57.19 MPH	1st gear High Speed (Low Axle Gear)	N/A
2nd gear High Speed (Low Axle Gear)	N/A	3rd gear High Speed (Low Axle Gear)	N/A
4th gear High Speed (Low Axle Gear)	N/A	5th gear High Speed (Low Axle Gear)	N/A
6th gear High Speed (Low Axle Gear)	N/A	1st gear Low Speed (Low Axle Gear)	N/A
2nd gear Low Speed (Low Axle Gear)	N/A	3rd gear Low Speed (Low Axle Gear)	N/A
4th gear Low Speed (Low Axle Gear)	N/A	5th gear Low Speed (Low Axle Gear)	N/A
6th gear Low Speed (Low Axle Gear)	N/A	Reduction	23.51
Torque @ Clutch Engage	N/A	Starting Grade Index	N/A
1st Gear Tractive Effort (High Axle Gear)	6210.71	2nd Gear Tractive Effort (High Axle Gear)	3606.22
3rd Gear Tractive Effort (High Axle Gear)	2804.84	4th Gear Tractive Effort (High Axle Gear)	2003.46
5th Gear Tractive Effort (High Axle Gear)	1402.42	6th Gear Tractive Effort (High Axle Gear)	1222.11
1st Gear Tractive Effort (Low Axle Gear)	N/A	2nd Gear Tractive Effort (Low Axle Gear)	N/A
3rd Gear Tractive Effort (Low Axle Gear)	N/A	4th Gear Tractive Effort (Low Axle Gear)	N/A
5th Gear Tractive Effort (Low Axle Gear)	N/A	6th Gear Tractive Effort (Low Axle Gear)	N/A
1st Gear Gradeability (High Axle Gear)	28.85	2nd Gear Gradeability (High Axle Gear)	15.75
3rd Gear Gradeability (High Axle Gear)	11.31	4th Gear Gradeability (High Axle Gear)	6.03
5th Gear Gradeability (High Axle Gear)	0.14	6th Gear Gradeability (High Axle Gear)	-2.57
1st Gear Gradeability (Low Axle Gear)	53.23	2nd Gear Gradeability (Low Axle Gear)	30.44
3rd Gear Gradeability (Low Axle Gear)	23.29	4th Gear Gradeability (Low Axle Gear)	15.88
5th Gear Gradeability (Low Axle Gear)	9.72	6th Gear Gradeability (Low Axle Gear)	7.58

This document contains information considered Confidential between GM and its Clients uniquely. The information provided is not intended for public disclosure. Prices, specifications, and availability are subject to change without notice, and do not include certain fees, taxes and charges that may be required by law or vary by manufacturer or region. Performance figures are guidelines only, and actual performance may vary. Photos may not represent actual vehicles or exact configurations. Content based on report preparer's input is subject to the accuracy of the input provided.

Data Version: 10374. Data Updated: Feb 20, 2020 10:40:00 PM PST.



Wilson County Motors

Sabrina Edwards | 615-444-9642 | Sabrina@wilsoncountyauto.com

Vehicle: [Fleet] 2020 Chevrolet Silverado MD (CK56403) 4WD Reg Cab Work Truck (✔ Complete)

Medium Duty

Medium Duty Performance

Geared Road Speed	103.65 MPH	Actual Loaded Speed	63.2 MPH In 4th Hi @ 2900 RPM MPH
Grade (%)	2.0	Maximum Speed Gradeability	15.05% @ 2528 RPM @ 75 MPH
Torque Converter	1.764	Maximum Capacity @ 0° F	2200.00
% of Body on Front Axle	49.01	% of Body on Rear Axle	50.99
Body Weight Front	0.00 lbs	Body Weight Rear	0.00 lbs
Actual Loaded Speed (First Part, MPH)	63.2 MPH	Actual Loaded Speed (Second Part, RPM)	2900
Actual Loaded Speed (Third Part, Gear)	4	Road Type	Concrete
Body Weight	0.0 lbs	Driver Weight Front	350.00 lbs
Driver Weight Rear	0.00 lbs	Medium Duty Body Type	None
Front Total Load	5744.00 lbs	Rear Total Load	3121.00 lbs

This document contains information considered Confidential between GM and its Clients uniquely. The information provided is not intended for public disclosure. Prices, specifications, and availability are subject to change without notice, and do not include certain fees, taxes and charges that may be required by law or vary by manufacturer or region. Performance figures are guidelines only, and actual performance may vary. Photos may not represent actual vehicles or exact configurations. Content based on report preparer's input is subject to the accuracy of the input provided.

Data Version: 10374. Data Updated: Feb 20, 2020 10:40:00 PM PST.



Wilson County Motors

Sabrina Edwards | 615-444-9642 | Sabrina@wilsoncountyauto.com

Vehicle: [Fleet] 2020 Chevrolet Silverado MD (CK56403) 4WD Reg Cab Work Truck (✔ Complete)

Weight Distribution

SPECIFICATION SUMMARY

Model #	CK56403
Truck/Tractor	
Wheelbase (WB)	165 in
Cab to Axle (CA)	83.86 in
Cab to Body/Swing Clear (BOC)	3.0 in
Body Length	0.0 ft
Body Weight	0.0 lbs
Cargo Weight	0.00 lbs
Front GAWR	7500 lbs
Rear GAWR	15000 lbs
GVWR	19500.00 lbs

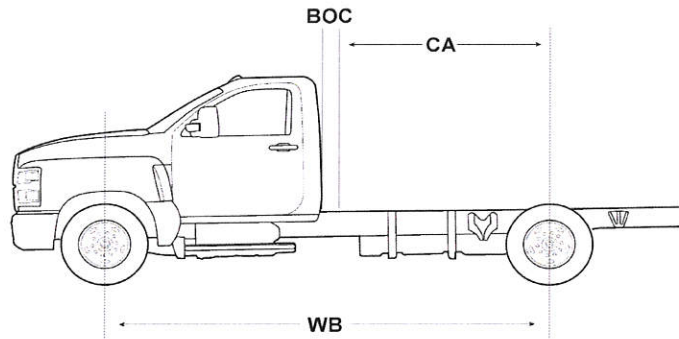

CA: 83.86 in
 BOC: 3.0 in
 WB: 165 in

Fr%: 64.79 Rr%: 35.21
Front Wt: 5744.00 lbs **Rear Wt: 3121.00 lbs**

GAWR/GVWR	GVW	Remaining Payload Wt
19500.00 lbs	8865.00 lbs	10,635.00 lbs

This document contains information considered Confidential between GM and its Clients uniquely. The information provided is not intended for public disclosure. Prices, specifications, and availability are subject to change without notice, and do not include certain fees, taxes and charges that may be required by law or vary by manufacturer or region. Performance figures are guidelines only, and actual performance may vary. Photos may not represent actual vehicles or exact configurations. Content based on report preparer's input is subject to the accuracy of the input provided.

Data Version: 10374. Data Updated: Feb 20, 2020 10:40:00 PM PST.



Wilson County Motors

Sabrina Edwards | 615-444-9642 | Sabrina@wilsoncountyauto.com

Vehicle: [Fleet] 2020 Chevrolet Silverado MD (CK56403) 4WD Reg Cab Work Truck (Complete)

Weight Distribution

SPECIFICATION DETAILS

	Front Axle	Rear Axle	Total
Actual			
Chassis	5394.00 lbs	3121.00 lbs	8515.00 lbs
Body	0.00 lbs	0.00 lbs	0.0 lbs
Payload	0.00 lbs	0.00 lbs	0.00 lbs
Trailer			0.0 lbs
Totals	5744.00 lbs	3121.00 lbs	8865.00 lbs
Capacity			
Axle	7500 lbs	15000 lbs	22500.00 lbs
Suspension	7500 lbs	15500 lbs	23,000.00 lbs
Tire	7940 lbs	15000 lbs	22940.00
Total Axle Rating	7500.00 lbs	15000.00 lbs	22500.00 lbs

This document contains information considered Confidential between GM and its Clients uniquely. The information provided is not intended for public disclosure. Prices, specifications, and availability are subject to change without notice, and do not include certain fees, taxes and charges that may be required by law or vary by manufacturer or region. Performance figures are guidelines only, and actual performance may vary. Photos may not represent actual vehicles or exact configurations. Content based on report preparer's input is subject to the accuracy of the input provided.

Data Version: 10374. Data Updated: Feb 20, 2020 10:40:00 PM PST.



Wilson County Motors

Sabrina Edwards | 615-444-9642 | Sabrina@wilsoncountyauto.com

Vehicle: [Fleet] 2020 Chevrolet Silverado MD (CK56403) 4WD Reg Cab Work Truck (Complete)

Selected Model and Options

MODEL

CODE	MODEL	VQ2	MSRP
CK56403	2020 Chevrolet Silverado MD 4WD Reg Cab Work Truck	\$46,705.40	\$51,100.00

COLORS

CODE	DESCRIPTION	VQ2	MSRP
GAZ	Summit White	\$0.00	\$0.00

MODEL OPTION

CODE	DESCRIPTION	VQ2	MSRP
R7N	5500 HD Series (Included and only available with (GZX) 17,500 lbs. GVWR, (GZJ) 18,000 lbs. GVWR or (GZG) 19,500 lbs. GVWR.)	Inc.	Inc.

GVWR

CODE	DESCRIPTION	VQ2	MSRP
GZG	GVWR, 19,500 lbs. (8845 kg) (Silverado 5500HD Requires (FTB) 7,500 lbs. front axle/(FTV) suspension and (HD2) 13,500 lbs. rear axle and (GR4) 13,500 lbs. rear suspension, or (FTB) 7,500 lbs. front axle/(FTV) suspension and (HD1) 15,000 lbs. rear axle and (FU7) 15,500 lbs. rear suspension.)	\$1,984.40	\$2,255.00

REQUIRED OPTION

CODE	DESCRIPTION	VQ2	MSRP
R6G	26,000 lbs. GCWR (11,793 kg) (Requires 26k GCWR transmission (MWA, MWB, MIU, MIA, MH1, MG0, MIX, MF0, MA6 or MB6).)	\$0.00	\$0.00

ENGINE

CODE	DESCRIPTION	VQ2	MSRP
L5D	Engine, Duramax 6.6L Turbo-Diesel V8, B20-Diesel compatible 350 hp @ 2700 rpm, 700 lb-ft torque @ 1600 rpm (STD)	\$0.00	\$0.00

POWER TAKE OFF

CODE	DESCRIPTION	VQ2	MSRP
PTX	Power Take-Off (PTO), not installed	\$0.00	\$0.00

This document contains information considered Confidential between GM and its Clients uniquely. The information provided is not intended for public disclosure. Prices, specifications, and availability are subject to change without notice, and do not include certain fees, taxes and charges that may be required by law or vary by manufacturer or region. Performance figures are guidelines only, and actual performance may vary. Photos may not represent actual vehicles or exact configurations. Content based on report preparer's input is subject to the accuracy of the input provided.

Data Version: 10374. Data Updated: Feb 20, 2020 10:40:00 PM PST.



Wilson County Motors

Sabrina Edwards | 615-444-9642 | Sabrina@wilsoncountyauto.com

Vehicle: [Fleet] 2020 Chevrolet Silverado MD (CK56403) 4WD Reg Cab Work Truck (✔ Complete)

TRANSMISSION

CODE	DESCRIPTION	VQ2	MSRP
MWA	Highway Service Transmission, Automatic close-ratio 6 SPD with double overdrive, Allison, A1700HS ratios: 3.10 1ST, 1.80 2ND, 1.40 3RD, 1.00 4TH, 0.70 5TH, 0.61 6TH Highway Series, 19.5K GVW & 26K GCW Max., requires PTX and park pawl. Available with GVWs less than or equal to 19.5K (Requires (C5B) 15,000 lbs. GVWR, (C7P) 16,000 lbs. GVWR, (C7R) 16,500 lbs. GVWR, (GZX) 17,500 lbs. GVWR, (GZJ) 18,000 lbs. GVWR or (GZG) 19,500 lbs. GVWR. Requires (R6G) 26,000 lbs. GCWR (11,793 kg.) (STD)	\$0.00	\$0.00

AXLE

CODE	DESCRIPTION	VQ2	MSRP
092	Rear axle, 4.30 ratio Max road speed: 75 MPH	\$0.00	\$0.00

FRONT AXLE

CODE	DESCRIPTION	VQ2	MSRP
FTB	Front axle, 7,500 lbs., Dana Spicer 60-256, single-reduction, front driving	\$0.00	\$0.00

REAR AXLE

CODE	DESCRIPTION	VQ2	MSRP
HD1	Rear axle, 15,000 lbs. (6,804 kg) Dana Spicer S16-130, single reduction	\$594.00	\$675.00

REAR SUSPENSION

CODE	DESCRIPTION	VQ2	MSRP
FU7	Rear suspension, 15,500 lbs. (7,031 kg) multi-leaf, vari-rate (Requires (PCJ) Vocational Specific Heavy Suspension Package when ordered with (ED9) 165" Wheelbase.)	\$44.00	\$50.00

WHEELBASE

CODE	DESCRIPTION	VQ2	MSRP
ED9	Wheelbase, 165" (419.1 cm), 84" CA (Requires (FOC) 49" axle to end of frame, (FOD) 63" axle to end of frame, (FOK) 91" axle to end of frame. Requires (PCJ) Vocational Specific Heavy Suspension Package, when ordering (FTA) 7,000 lbs. Front axle/(FK6) 7,000 lbs. Front suspension or (FTL) 8,000 lbs. Front axle/(FSN) 8,000 lbs. Front suspension or (FU7) 15,500 lbs. rear suspension.) (STD)	\$0.00	\$0.00

PREFERRED EQUIPMENT GROUP

CODE	DESCRIPTION	VQ2	MSRP
1WT	Work Truck Preferred Equipment Group includes standard equipment	\$0.00	\$0.00

This document contains information considered Confidential between GM and its Clients uniquely. The information provided is not intended for public disclosure. Prices, specifications, and availability are subject to change without notice, and do not include certain fees, taxes and charges that may be required by law or vary by manufacturer or region. Performance figures are guidelines only, and actual performance may vary. Photos may not represent actual vehicles or exact configurations. Content based on report preparer's input is subject to the accuracy of the input provided.

Data Version: 10374. Data Updated: Feb 20, 2020 10:40:00 PM PST.



Wilson County Motors

Sabrina Edwards | 615-444-9642 | Sabrina@wilsoncountyauto.com

Vehicle: [Fleet] 2020 Chevrolet Silverado MD (CK56403) 4WD Reg Cab Work Truck (✔ Complete)

WHEEL TYPE

CODE	DESCRIPTION	VQ2	MSRP
PWQ	Wheels, 19.5" x 6.75", steel, Black painted, 8-holes, hub piloted (STD)	\$0.00	\$0.00

FRONT TIRES

CODE	DESCRIPTION	VQ2	MSRP
XDK	Tires, front 225/70R19.5G highway blackwall Goodyear Max Axle Load: 7,940 lbs. (Requires (YAL) Tires, rear 225/70R19.5G highway blackwall Goodyear, Max Axle Load: 15,000 lbs. or (YAO) Tires, rear 225/70R19.5G traction blackwall Goodyear, Max Axle Load: 15,000 lbs.) (STD)	\$0.00	\$0.00

REAR TIRES

CODE	DESCRIPTION	VQ2	MSRP
YAL	Tires, rear 225/70R19.5G highway blackwall Goodyear Max Axle Load: 15,000 lbs. (STD)	\$0.00	\$0.00

SPARE TIRE

CODE	DESCRIPTION	VQ2	MSRP
9L3	Spare tire delete (STD)	\$0.00	\$0.00

PAINT SCHEME

CODE	DESCRIPTION	VQ2	MSRP
ZY1	Paint, solid	\$0.00	\$0.00

PAINT

CODE	DESCRIPTION	VQ2	MSRP
GAZ	Summit White	\$0.00	\$0.00

SEAT TYPE

CODE	DESCRIPTION	VQ2	MSRP
AE7	Seats, front 40/20/40 split-bench, 3-passenger driver and front passenger recline with outboard head restraints and center fold-down armrest with storage. Vinyl has fixed lumbar and cloth has manually adjustable driver lumbar. (STD)	\$0.00	\$0.00

SEAT TRIM

CODE	DESCRIPTION	VQ2	MSRP
H2Q	Dark Ash seats with Jet Black interior accents, Vinyl seat trim	\$0.00	\$0.00

This document contains information considered Confidential between GM and its Clients uniquely. The information provided is not intended for public disclosure. Prices, specifications, and availability are subject to change without notice, and do not include certain fees, taxes and charges that may be required by law or vary by manufacturer or region. Performance figures are guidelines only, and actual performance may vary. Photos may not represent actual vehicles or exact configurations. Content based on report preparer's input is subject to the accuracy of the input provided.

Data Version: 10374. Data Updated: Feb 20, 2020 10:40:00 PM PST.



Wilson County Motors

Sabrina Edwards | 615-444-9642 | Sabrina@wilsoncountyauto.com

Vehicle: [Fleet] 2020 Chevrolet Silverado MD (CK56403) 4WD Reg Cab Work Truck (Complete)

AIR CONDITIONING

CODE	DESCRIPTION	VQ2	MSRP
C67	Air conditioning, single-zone (STD)	\$0.00	\$0.00

RADIO

CODE	DESCRIPTION	VQ2	MSRP
IO3	Audio system, 4.2" diagonal color display AM/FM stereo with USB port and auxiliary jack (Requires (AE7) front 40/20/40 split-bench seat. Not available with (UE1) OnStar or (U2K) SiriusXM Radio.) (STD)	\$0.00	\$0.00

ADDITIONAL EQUIPMENT - PACKAGE

CODE	DESCRIPTION	VQ2	MSRP
PCJ	Vocational Specific Heavy Suspension Package For 165" WB trucks only. Allows the selection of 7,000 lbs., 8,000 lbs., front axles and/or 15,500 lbs. rear spring suspension on trucks that will be upfitted with the following vocational bodies: Utility/Service Bodies, Aerial Lift/Bucket bodies, Front Plow/Rear Spreader Applications, and Landscape Dump Bodies (Requires (ED9) 165" Wheelbase and (FU7) 15,500 lbs. rear suspension.)	\$0.00	\$0.00

ADDITIONAL EQUIPMENT - SAFETY-INTERIOR

CODE	DESCRIPTION	VQ2	MSRP
UVC	Rear Vision Camera, display integrated into Radio	\$176.00	\$200.00

ADDITIONAL EQUIPMENT - OTHER

CODE	DESCRIPTION	VQ2	MSRP
VQ2	Fleet Processing Option	\$0.00	\$0.00

CUSTOM EQUIPMENT

CODE	DESCRIPTION	VQ2	MSRP
After Mkt	Service Body	\$12,687.40	\$0.00
Assistance	Additional Assistance	(\$900.00)	\$0.00
Fed Tire	Federal Tire Fee	\$10.00	\$0.00
Gov Asst	Government Assistance	(\$6,500.00)	\$0.00
Options Total		\$8,095.80	\$3,180.00

This document contains information considered Confidential between GM and its Clients uniquely. The information provided is not intended for public disclosure. Prices, specifications, and availability are subject to change without notice, and do not include certain fees, taxes and charges that may be required by law or vary by manufacturer or region. Performance figures are guidelines only, and actual performance may vary. Photos may not represent actual vehicles or exact configurations. Content based on report preparer's input is subject to the accuracy of the input provided.

Data Version: 10374. Data Updated: Feb 20, 2020 10:40:00 PM PST.



Wilson County Motors

Sabrina Edwards | 615-444-9642 | Sabrina@wilsoncountyauto.com

Vehicle: [Fleet] 2020 Chevrolet Silverado MD (CK56403) 4WD Reg Cab Work Truck (✔ Complete)

Standard Equipment

Mechanical

4500 HD Series (Included and only available with (C5B) 15,000 lbs. GVWR, (C7P) 16,000 lbs. GVWR or (C7R) 16,500 lbs. GVWR.) (STD)

GVWR, 16,500 lbs. (7484 kg) (Silverado 4500HD Requires (FTB) 7,500 lbs. front axle/(FTV) suspension and (FN1) 10,000 lbs. rear axle or (GL4) 11,000 lbs. rear axle and (GR3) 11,000 lbs. rear suspension, or (FTB) 7,500 lbs. front axle/(FTV) front suspension and (FU7) 15,500 lbs. rear suspension and (HD1) 15,000 lbs. rear axle.) (STD)

Emissions, 50 state certification

Emissions, USA 50 State certified

Engine, Duramax 6.6L Turbo-Diesel V8, B20-Diesel compatible 350 hp @ 2700 rpm, 700 lb-ft torque @ 1600 rpm (STD)

Highway Service Transmission, Automatic close-ratio 6 SPD with double overdrive, Allison, A1700HS ratios: 3.10 1ST, 1.80 2ND, 1.40 3RD, 1.00 4TH, 0.70 5TH, 0.61 6TH Highway Series, 19.5K GVW & 26K GCW Max., requires PTX and park pawl. Available with GVWs less than or equal to 19.5K (Requires (C5B) 15,000 lbs. GVWR, (C7P) 16,000 lbs. GVWR, (C7R) 16,500 lbs. GVWR, (GZX) 17,500 lbs. GVWR, (GZJ) 18,000 lbs. GVWR or (GZG) 19,500 lbs. GVWR. Requires (R6G) 26,000 lbs. GCWR (11,793 kg).) (STD)

Rear axle, 4.30 ratio Max road speed: 75 MPH

Front axle, 7,500 lbs., Dana Spicer 60-256, single-reduction, front driving

Front suspension, 7,500 lbs. (3,402 kg) multi-leaf, includes shock absorbers

Wheelbase, 165" (419.1 cm), 84" CA (Requires (F0C) 49" axle to end of frame, (F0D) 63" axle to end of frame, (F0K) 91" axle to end of frame. Requires (PCJ) Vocational Specific Heavy Suspension Package, when ordering (FTA) 7,000 lbs. Front axle/(FK6) 7,000 lbs. Front suspension or (FTL) 8,000 lbs. Front axle/(FSN) 8,000 lbs. Front suspension or (FU7) 15,500 lbs. rear suspension.) (STD)

Rear axle, 11,000 lbs. (4,999 kg) Dana Spicer S14-110, single reduction

Rear suspension, 11,000 (4,990 kg) multi-leaf, vari-rate (STD)

Transmission shift control calibration, fuel sense Performance

Axle, limited slip, Dana Spicer Truetrac, torque proportioning limited slip

Four wheel drive

Batteries, heavy-duty dual 1100 cold-cranking amps includes battery box mounted to left side under cab

Alternator, 150 amps

Incomplete vehicle

Axle to End of Frame, 49" (Requires wheelbase (ED5) 201", (ED9) 165" or (ER2) 189". Not available with (G40), (GP1) or (GP8) rear air suspension.)

Axle lubricant, front, synthetic oil EmGard FE-75W-90

Axle lubricant, rear, synthetic oil EmGard FE -75W-90

Steering, power (Bosch S2 8014 Plus)

This document contains information considered Confidential between GM and its Clients uniquely. The information provided is not intended for public disclosure. Prices, specifications, and availability are subject to change without notice, and do not include certain fees, taxes and charges that may be required by law or vary by manufacturer or region. Performance figures are guidelines only, and actual performance may vary. Photos may not represent actual vehicles or exact configurations. Content based on report preparer's input is subject to the accuracy of the input provided.

Data Version: 10374. Data Updated: Feb 20, 2020 10:40:00 PM PST.



Wilson County Motors

Sabrina Edwards | 615-444-9642 | Sabrina@wilsoncountyauto.com

Vehicle: [Fleet] 2020 Chevrolet Silverado MD (CK56403) 4WD Reg Cab Work Truck ( Complete)

Mechanical

Brakes, hydraulic, heavy duty Bosch/Meritor/Wabco system with 4-channel (ABS) (Includes (J69) driveline park brake.)

Fuel tank, rear only, 40 gallon mounted between frame side rails and behind rear axle

Fuel, diesel B20

Capped Fuel Fill

Exhaust system, rear exit

Exterior

Wheels, 19.5" x 6.75", steel, Black painted, 8-holes, hub piloted (STD)

Tires, front 225/70R19.5G highway blackwall Goodyear Max Axle Load: 7,940 lbs. (Requires (YAL) Tires, rear 225/70R19.5G highway blackwall Goodyear, Max Axle Load: 15,000 lbs. or (YAO) Tires, rear 225/70R19.5G traction blackwall Goodyear, Max Axle Load: 15,000 lbs.) (STD)

Tires, rear 225/70R19.5G highway blackwall Goodyear Max Axle Load: 15,000 lbs. (STD)

Spare tire delete (STD)

Wheel, spare delete

Bumper, front, Black

Assist steps

Front fender extension, mold-in-color Black (Not available with (FNP) Body color front fender extension.)

Grille, base, molded in color, Black

Grille guard screen, insect protection (mounted behind grille)

Headlamps, halogen projector-beam

Lamps, cargo area, cab mounted with switch on center switch bank

Lamps, Smoked Amber roof marker

Lamps, rear, stop/turn/backup (1-piece assembly) with license plate light

Mirrors, outside high-visibility vertical camper-style, Black with manual folding and extension and lower convex spotter glass

Glass, solar absorbing, tinted

Antenna, fixed mast

Door handles, Black

Entertainment

Audio system, 4.2" diagonal color display AM/FM stereo with USB port and auxiliary jack (Requires (AE7) front 40/20/40 split-bench seat. Not available with (UE1) OnStar or (U2K) SiriusXM Radio.) (STD)

SiriusXM, delete

Audio system feature, 4-speaker system

This document contains information considered Confidential between GM and its Clients uniquely. The information provided is not intended for public disclosure. Prices, specifications, and availability are subject to change without notice, and do not include certain fees, taxes and charges that may be required by law or vary by manufacturer or region. Performance figures are guidelines only, and actual performance may vary. Photos may not represent actual vehicles or exact configurations. Content based on report preparer's input is subject to the accuracy of the input provided.

Data Version: 10374. Data Updated: Feb 20, 2020 10:40:00 PM PST.



Wilson County Motors

Sabrina Edwards | 615-444-9642 | Sabrina@wilsoncountyauto.com

Vehicle: [Fleet] 2020 Chevrolet Silverado MD (CK56403) 4WD Reg Cab Work Truck (✔ Complete)

Interior

Seats, front 40/20/40 split-bench, 3-passenger driver and front passenger recline with outboard head restraints and center fold-down armrest with storage. Vinyl has fixed lumbar and cloth has manually adjustable driver lumbar. (STD)

Air conditioning, single-zone (STD)

Interior trim, Jet Black/Dark Ash (Required and only available with (H2Q/H2R) Dark Ash seats with Jet Black interior accents.)

Seat trim, Vinyl

Seat Belt, Black

Floor covering, Graphite-colored rubberized-vinyl

Steering wheel, urethane

Steering column, manual Tilt-Wheel

Instrumentation, 6-gauge cluster featuring speedometer, fuel level, engine temperature, tachometer, voltage and oil pressure

Speedometer, miles/kilometers

Driver Information Center, 3.5-inch diagonal monochromatic display, provides warning messages and basic vehicle information

Windows, manual driver and front passenger

Door locks, power

Cruise control, steering wheel-mounted

Mirror, inside rearview manual day/night

Visors, driver and front passenger, vinyl

Assist handle, front passenger and driver on A-pillars

Safety-Mechanical

Brake, parking, driveline park brake system

Traction control

Safety-Exterior

Daytime Running Lamps, with automatic exterior lamp control

Safety-Interior

Airbags, Single-stage frontal airbags for driver and front outboard passenger; Seat-mounted side-impact airbags for driver and front outboard passenger; Head-curtain airbags for front outboard seating positions; Includes airbag deactivation switch for front outboard passenger airbag (Always use seat belts and child restraints. Children are safer when properly secured in a rear seat in the appropriate child restraint. See the Owner's Manual for more information.)

Airbag deactivation switch, frontal passenger-side (Included and only available with (AY0) airbags.)

This document contains information considered Confidential between GM and its Clients uniquely. The information provided is not intended for public disclosure. Prices, specifications, and availability are subject to change without notice, and do not include certain fees, taxes and charges that may be required by law or vary by manufacturer or region. Performance figures are guidelines only, and actual performance may vary. Photos may not represent actual vehicles or exact configurations. Content based on report preparer's input is subject to the accuracy of the input provided.

Data Version: 10374. Data Updated: Feb 20, 2020 10:40:00 PM PST.



Wilson County Motors

Sabrina Edwards | 615-444-9642 | Sabrina@wilsoncountyauto.com

Vehicle: [Fleet] 2020 Chevrolet Silverado MD (CK56403) 4WD Reg Cab Work Truck ( Complete)

Safety-Interior

OnStar, delete

Horn, single-note

WARRANTY

Warranty Note: <<< Preliminary 2020 Warranty Note >>>

Basic Years: 3

Basic Miles/km: 36,000

Drivetrain Years (Allison Basic): 5

Drivetrain Years: 5

Drivetrain Miles/km (Allison Basic): Unlimited

Drivetrain Miles/km: 100,000

Drivetrain Note: Duramax Diesel

Corrosion Years (Rust-Through): 6

Corrosion Years: 3

Corrosion Miles/km (Rust-Through): 100,000

Corrosion Miles/km: 36,000

Roadside Assistance Years: 5

Roadside Assistance Miles/km: 100,000

Maintenance Note: 1 Year/1 Visit

This document contains information considered Confidential between GM and its Clients uniquely. The information provided is not intended for public disclosure. Prices, specifications, and availability are subject to change without notice, and do not include certain fees, taxes and charges that may be required by law or vary by manufacturer or region. Performance figures are guidelines only, and actual performance may vary. Photos may not represent actual vehicles or exact configurations. Content based on report preparer's input is subject to the accuracy of the input provided.

Data Version: 10374. Data Updated: Feb 20, 2020 10:40:00 PM PST.



Wilson County Motors

Sabrina Edwards | 615-444-9642 | Sabrina@wilsoncountyauto.com

Vehicle: [Fleet] 2020 Chevrolet Silverado MD (CK56403) 4WD Reg Cab Work Truck (✔ Complete)

Geared Road Speed

SPECIFICATION SUMMARY

Model #	CK56403
Engine Order Code	L5D
Model Manufacturer	Duramax
Type	Turbocharged Diesel V8
Displacement	6.6L/402
Horsepower	350 @ 2700
Starting Torque	N/A
Transmission Order Code	MWA
Model Manufacturer	Allison
Type	6-Speed Automatic
Rear Axle Order Code	HD1
Model Manufacturer	A1700HS Allison
Weight Rating	15000 lbs
Ratio:1	4.30
Rear Tires	225/70R19.5G
Revolutions/Mile Front	640
Revolutions/Mile Rear	640
Surface Type	Concrete
Desired Grade	2%

Geared Road Speed



0% Grade in 4th gear

Actual Loaded Speed

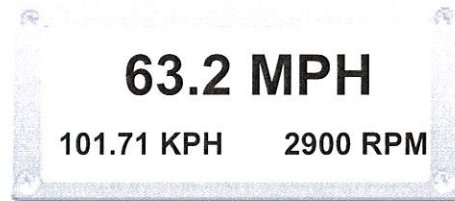

2% Grade in 4th gear

Note: Simulated speedometer appearance may not correspond with selected equipment.

This document contains information considered Confidential between GM and its Clients uniquely. The information provided is not intended for public disclosure. Prices, specifications, and availability are subject to change without notice, and do not include certain fees, taxes and charges that may be required by law or vary by manufacturer or region. Performance figures are guidelines only, and actual performance may vary. Photos may not represent actual vehicles or exact configurations. Content based on report preparer's input is subject to the accuracy of the input provided.

Data Version: 10374. Data Updated: Feb 20, 2020 10:40:00 PM PST.



Wilson County Motors

Sabrina Edwards | 615-444-9642 | Sabrina@wilsoncountyauto.com

Vehicle: [Fleet] 2020 Chevrolet Silverado MD (CK56403) 4WD Reg Cab Work Truck (Complete)

Gradeability Chart

SPECIFICATION SUMMARY

Model #	CK56403
Engine Order Code	L5D
Model Manufacturer	Duramax
Type	Turbocharged Diesel V8
Displacement	6.6L/402
Horsepower	350 @ 2700
Starting Torque	N/A
Transmission Order Code	MWA
Model Manufacturer	Allison
Type	6-Speed Automatic
Rear Axle Order Code	HD1
Model Manufacturer	A1700HS Allison
Weight Rating	15000 lbs
Ratio:1	4.30
Rear Tires	225/70R19.5G
Revolutions/Mile Front	640
Revolutions/Mile Rear	640
Surface Type	Concrete
Desired Grade	2%

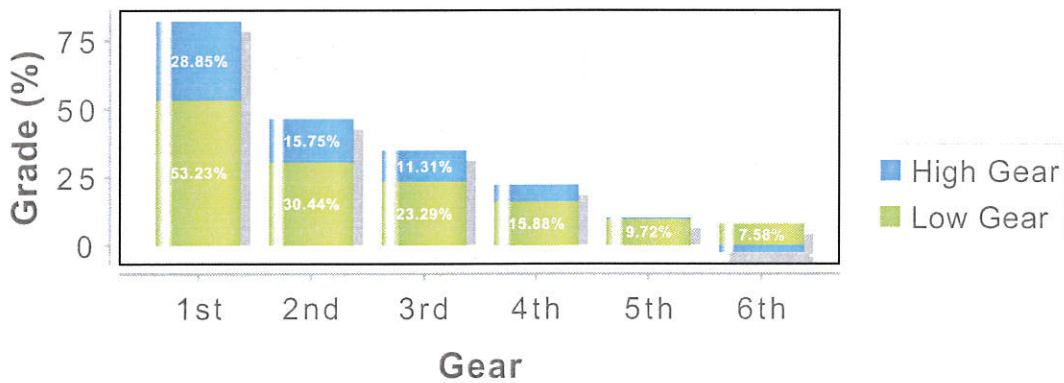

This document contains information considered Confidential between GM and its Clients uniquely. The information provided is not intended for public disclosure. Prices, specifications, and availability are subject to change without notice, and do not include certain fees, taxes and charges that may be required by law or vary by manufacturer or region. Performance figures are guidelines only, and actual performance may vary. Photos may not represent actual vehicles or exact configurations. Content based on report preparer's input is subject to the accuracy of the input provided.

Data Version: 10374. Data Updated: Feb 20, 2020 10:40:00 PM PST.



Wilson County Motors

Sabrina Edwards | 615-444-9642 | Sabrina@wilsoncountyauto.com

Vehicle: [Fleet] 2020 Chevrolet Silverado MD (CK56403) 4WD Reg Cab Work Truck (✔ Complete)

Turning Circle

SPECIFICATION SUMMARY

Model #	CK56403
Front Axle Order Code	FTB
Capacity (lbs)	7500 lbs
Wheelbase Order Code	ED9
Wheelbase (in)	165 in
Front Wheel Order Code	
Size/Type (in)	19.5 x 6.75 in
Front Tire Order Code	XDK
Size/Type	225/70R19.5G

Wall to Wall (ft): 53.6 ft

Wall to Wall diameter is measured from the outermost part of the cab.

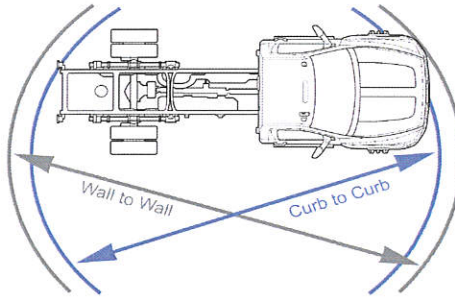

Curb to Curb (ft): 52 ft

Curb to Curb diameter is measured from the outside of the front tire.

This document contains information considered Confidential between GM and its Clients uniquely. The information provided is not intended for public disclosure. Prices, specifications, and availability are subject to change without notice, and do not include certain fees, taxes and charges that may be required by law or vary by manufacturer or region. Performance figures are guidelines only, and actual performance may vary. Photos may not represent actual vehicles or exact configurations. Content based on report preparer's input is subject to the accuracy of the input provided.

Data Version: 10374. Data Updated: Feb 20, 2020 10:40:00 PM PST.



Wilson County Motors

Sabrina Edwards | 615-444-9642 | Sabrina@wilsoncountyauto.com

Vehicle: [Fleet] 2020 Chevrolet Silverado MD (CK56403) 4WD Reg Cab Work Truck ( Complete)



Note:Photo may not represent exact vehicle or selected equipment.

This document contains information considered Confidential between GM and its Clients uniquely. The information provided is not intended for public disclosure. Prices, specifications, and availability are subject to change without notice, and do not include certain fees, taxes and charges that may be required by law or vary by manufacturer or region. Performance figures are guidelines only, and actual performance may vary. Photos may not represent actual vehicles or exact configurations. Content based on report preparer's input is subject to the accuracy of the input provided.

Data Version: 10374. Data Updated: Feb 20, 2020 10:40:00 PM PST.



Wilson County Motors

Sabrina Edwards | 615-444-9642 | Sabrina@wilsoncountyauto.com

Trousdale County

Vehicle: [Fleet] 2020 Chevrolet Silverado 1500 (CK10743) 4WD Crew Cab 157" Work Truck





Wilson County Motors

Sabrina Edwards | 615-444-9642 | Sabrina@wilsoncountyauto.com

Wilson County Motors

Prepared By:

Sabrina Edwards
Wilson County Motors
615-444-9642
Sabrina@wilsoncountyauto.com

This document contains information considered Confidential between GM and its Clients uniquely. The information provided is not intended for public disclosure. Prices, specifications, and availability are subject to change without notice, and do not include certain fees, taxes and charges that may be required by law or vary by manufacturer or region. Performance figures are guidelines only, and actual performance may vary. Photos may not represent actual vehicles or exact configurations. Content based on report preparer's input is subject to the accuracy of the input provided.
Data Version: 10301. Data Updated: Feb 10, 2020 10:26:00 PM PST.



Wilson County Motors

Sabrina Edwards | 615-444-9642 | Sabrina@wilsoncountyauto.com

Vehicle: [Fleet] 2020 Chevrolet Silverado 1500 (CK10743) 4WD Crew Cab 157" Work Truck ( Complete)

Price Summary

PRICE SUMMARY

	VQ2	MSRP
Base Price	\$35,564.20	\$38,200.00
Total Options	(\$8,216.60)	\$2,335.00
Vehicle Subtotal	\$27,347.60	\$40,535.00
Destination Charge	\$1,595.00	\$1,595.00
Grand Total	\$28,942.60	\$42,130.00

This document contains information considered Confidential between GM and its Clients uniquely. The information provided is not intended for public disclosure. Prices, specifications, and availability are subject to change without notice, and do not include certain fees, taxes and charges that may be required by law or vary by manufacturer or region. Performance figures are guidelines only, and actual performance may vary. Photos may not represent actual vehicles or exact configurations. Content based on report preparer's input is subject to the accuracy of the input provided.

Data Version: 10301. Data Updated: Feb 10, 2020 10:26:00 PM PST.



Wilson County Motors

Sabrina Edwards | 615-444-9642 | Sabrina@wilsoncountyauto.com

Vehicle: [Fleet] 2020 Chevrolet Silverado 1500 (CK10743) 4WD Crew Cab 157" Work Truck ( Complete)

Technical Specifications

This document contains information considered Confidential between GM and its Clients uniquely. The information provided is not intended for public disclosure. Prices, specifications, and availability are subject to change without notice, and do not include certain fees, taxes and charges that may be required by law or vary by manufacturer or region. Performance figures are guidelines only, and actual performance may vary. Photos may not represent actual vehicles or exact configurations. Content based on report preparer's input is subject to the accuracy of the input provided.

Data Version: 10301. Data Updated: Feb 10, 2020 10:26:00 PM PST.



Wilson County Motors

Sabrina Edwards | 615-444-9642 | Sabrina@wilsoncountyauto.com

Vehicle: [Fleet] 2020 Chevrolet Silverado 1500 (CK10743) 4WD Crew Cab 157" Work Truck (✔ Complete)

Selected Model and Options

MODEL

CODE	MODEL	VQ2	MSRP
CK10743	2020 Chevrolet Silverado 1500 4WD Crew Cab 157" Work Truck	\$35,564.20	\$38,200.00

COLORS

CODE	DESCRIPTION	VQ2	MSRP
GAZ	Summit White	\$0.00	\$0.00

EMISSIONS

CODE	DESCRIPTION	VQ2	MSRP
FE9	Emissions, Federal requirements	\$0.00	\$0.00

ENGINE

CODE	DESCRIPTION	VQ2	MSRP
L82	Engine, 5.3L EcoTec3 V8 with Active Fuel Management, (355 hp [265 kW] @ 5600 rpm, 383 lb-ft of torque [518 Nm] @ 4100 rpm)	\$1,227.60	\$1,395.00

TRANSMISSION

CODE	DESCRIPTION	VQ2	MSRP
MYC	Transmission, 6-speed automatic, electronically controlled (STD)	\$0.00	\$0.00

GVWR

CODE	DESCRIPTION	VQ2	MSRP
C5Y	GVWR, 7100 lbs. (3221 kg) (Requires Crew Cab 4WD model with (L82) 5.3L EcoTec3 V8 engine.)	Inc.	Inc.

AXLE

CODE	DESCRIPTION	VQ2	MSRP
GU6	Rear axle, 3.42 ratio	\$0.00	\$0.00

PREFERRED EQUIPMENT GROUP

CODE	DESCRIPTION	VQ2	MSRP
1WT	Work Truck Preferred Equipment Group includes standard equipment	\$0.00	\$0.00

This document contains information considered Confidential between GM and its Clients uniquely. The information provided is not intended for public disclosure. Prices, specifications, and availability are subject to change without notice, and do not include certain fees, taxes and charges that may be required by law or vary by manufacturer or region. Performance figures are guidelines only, and actual performance may vary. Photos may not represent actual vehicles or exact configurations. Content based on report preparer's input is subject to the accuracy of the input provided.

Data Version: 10301. Data Updated: Feb 10, 2020 10:26:00 PM PST.



Wilson County Motors

Sabrina Edwards | 615-444-9642 | Sabrina@wilsoncountyauto.com

Vehicle: [Fleet] 2020 Chevrolet Silverado 1500 (CK10743) 4WD Crew Cab 157" Work Truck (✔ Complete)

WHEELS

CODE	DESCRIPTION	VQ2	MSRP
RD6	Wheels, 17" x 8" (43.2 cm x 20.3 cm) Ultra Silver painted steel (STD)	\$0.00	\$0.00

TIRES

CODE	DESCRIPTION	VQ2	MSRP
QBN	Tires, 255/70R17 all-season, blackwall (STD)	\$0.00	\$0.00

SPARE TIRE

CODE	DESCRIPTION	VQ2	MSRP
QBR	Tire, spare 255/70R17 all-season, blackwall (STD) (Included with (QBN) 255/70R17 all-season, blackwall tires.)	\$0.00	\$0.00

PAINT

CODE	DESCRIPTION	VQ2	MSRP
GAZ	Summit White	\$0.00	\$0.00

SEAT TYPE

CODE	DESCRIPTION	VQ2	MSRP
A52	Seats, front 40/20/40 split-bench (STD)	\$0.00	\$0.00

SEAT TRIM

CODE	DESCRIPTION	VQ2	MSRP
H2G	Jet Black, Vinyl seat trim	\$0.00	\$0.00

RADIO

CODE	DESCRIPTION	VQ2	MSRP
IOR	Audio system, Chevrolet Infotainment 3 system 7" diagonal color touchscreen, AM/FM stereo. Additional features for compatible phones include: Bluetooth audio streaming for 2 active devices, voice command pass-through to phone, Apple CarPlay and Android Auto capable. (STD)	\$0.00	\$0.00

ADDITIONAL EQUIPMENT - PACKAGE

CODE	DESCRIPTION	VQ2	MSRP
Z82	Trailer Package includes trailer hitch, 7-pin and 4-pin connectors and (CTT) Hitch Guidance (Included with (PEB) WT Value Package.)	\$347.60	\$395.00

This document contains information considered Confidential between GM and its Clients uniquely. The information provided is not intended for public disclosure. Prices, specifications, and availability are subject to change without notice, and do not include certain fees, taxes and charges that may be required by law or vary by manufacturer or region. Performance figures are guidelines only, and actual performance may vary. Photos may not represent actual vehicles or exact configurations. Content based on report preparer's input is subject to the accuracy of the input provided.

Data Version: 10301. Data Updated: Feb 10, 2020 10:26:00 PM PST.



Wilson County Motors

Sabrina Edwards | 615-444-9642 | Sabrina@wilsoncountyauto.com

Vehicle: [Fleet] 2020 Chevrolet Silverado 1500 (CK10743) 4WD Crew Cab 157" Work Truck (✔ Complete)

ADDITIONAL EQUIPMENT - MECHANICAL

CODE	DESCRIPTION	VQ2	MSRP
—	Battery, heavy-duty 720 cold-cranking amps/80 Amp-hr, maintenance-free with rundown protection and retained accessory power (Included and only available with (L82) 5.3L EcoTec3 V8 engine.)	Inc.	Inc.
G80	Differential, heavy-duty locking rear (Included with (Z71) Z71 Off-Road Package.)	\$347.60	\$395.00
KNP	Cooling, auxiliary external transmission oil cooler (Included and only available with V8 engines.)	Inc.	Inc.
NZZ	Skid Plates (Included with (BAQ) Work Truck Package, (Z71) Z71 Off-Road Package or (VYU) Snow Plow Prep Package.)	\$132.00	\$150.00

ADDITIONAL EQUIPMENT - SAFETY-INTERIOR

CODE	DESCRIPTION	VQ2	MSRP
CTT	Hitch Guidance (Included and only available with (Z82) Trailering Package.)	Inc.	Inc.

ADDITIONAL EQUIPMENT - OTHER

CODE	DESCRIPTION	VQ2	MSRP
VQ2	Fleet Processing Option	\$0.00	\$0.00

CUSTOM EQUIPMENT

CODE	DESCRIPTION	VQ2	MSRP
Assistance	Additional Assistance	(\$76.40)	\$0.00
Fed Tire	Federal Tire Fee	\$5.00	\$0.00
Gov Asst	Government Assistance	(\$10,200.00)	\$0.00
Options Total		(\$8,216.60)	\$2,335.00

This document contains information considered Confidential between GM and its Clients uniquely. The information provided is not intended for public disclosure. Prices, specifications, and availability are subject to change without notice, and do not include certain fees, taxes and charges that may be required by law or vary by manufacturer or region. Performance figures are guidelines only, and actual performance may vary. Photos may not represent actual vehicles or exact configurations. Content based on report preparer's input is subject to the accuracy of the input provided.

Data Version: 10301. Data Updated: Feb 10, 2020 10:26:00 PM PST.



Wilson County Motors

Sabrina Edwards | 615-444-9642 | Sabrina@wilsoncountyauto.com

Vehicle: [Fleet] 2020 Chevrolet Silverado 1500 (CK10743) 4WD Crew Cab 157" Work Truck (✔ Complete)

Standard Equipment

Mechanical

Durabed, pickup bed

Engine, 4.3L EcoTec3 V6 with Active Fuel Management, (285 hp [212 kW] @ 5300 rpm, 305 lb-ft of torque [413 Nm] @ 3900 rpm) (STD)

Transmission, 6-speed automatic, electronically controlled (STD)

Rear axle, 3.42 ratio

GVWR, 7000 lbs. (3175 kg) (STD) (Requires Crew Cab or Double Cab 4WD model and (LV3) 4.3L EcoTec3 V6 engine or (L3B) 2.7L Turbo engine.)

Transfer case, single speed electronic Autotrac with rotary dial control (4WD models only)

Four wheel drive

Cooling, external engine oil cooler (Not available with (L3B) 2.7L Turbo engine.)

Battery, heavy-duty 730 cold-cranking amps/70 Amp-hr, maintenance-free with rundown protection and retained accessory power (Included and only available with (LV3) 4.3L EcoTec3 V6 engine.)

Alternator, 170 amps

Frame, fully-boxed, hydroformed front section

Steering, Electric Power Steering (EPS) assist, rack-and-pinion

Brakes, 4-wheel antilock, 4-wheel disc with DURALIFE rotors

Brake lining wear indicator

Capless Fuel Fill

Exhaust, single outlet

Exterior

Wheels, 17" x 8" (43.2 cm x 20.3 cm) Ultra Silver painted steel (STD)

Tires, 255/70R17 all-season, blackwall (STD)

Tire, spare 255/70R17 all-season, blackwall (STD) (Included with (QBN) 255/70R17 all-season, blackwall tires.)

Tire carrier lock, keyed cylinder lock that utilizes same key as ignition and door

Bumpers, front, Black (semi-gloss)

Bumpers, rear, Black (semi-gloss)

CornerStep, rear bumper

Recovery hooks, front, frame-mounted, black (Included with 4WD models or on 2WD models with (PQA) WT Safety Package. Available free flow on 2WD models.)

Cargo tie downs (12), fixed rated at 500 lbs per corner

This document contains information considered Confidential between GM and its Clients uniquely. The information provided is not intended for public disclosure. Prices, specifications, and availability are subject to change without notice, and do not include certain fees, taxes and charges that may be required by law or vary by manufacturer or region. Performance figures are guidelines only, and actual performance may vary. Photos may not represent actual vehicles or exact configurations. Content based on report preparer's input is subject to the accuracy of the input provided.

Data Version: 10301. Data Updated: Feb 10, 2020 10:26:00 PM PST.



Wilson County Motors

Sabrina Edwards | 615-444-9642 | Sabrina@wilsoncountyauto.com

Vehicle: [Fleet] 2020 Chevrolet Silverado 1500 (CK10743) 4WD Crew Cab 157" Work Truck (✔ Complete)

Exterior

- Grille (Black bars and mesh inserts.)
- Headlamps, halogen reflector with halogen Daytime Running Lamps
- Lamps, cargo area, cab mounted integrated with center high mount stop lamp, with switch in bank on left side of steering wheel
- Taillamps, with incandescent tail, stop and reverse lights
- Mirrors, outside manual, Black
- Glass, solar absorbing, tinted
- Door handles, Black
- Tailgate and bed rail protection cap, top
- Tailgate, locking utilizes same key as ignition and door (Upgraded to (QT5) EZ Lift power lock and release tailgate when (ZLQ) WT Fleet Convenience Package or (PCV) WT Convenience Package is ordered.)
- Tailgate, gate function manual, no EZ Lift

Entertainment

- Audio system, Chevrolet Infotainment 3 system 7" diagonal color touchscreen, AM/FM stereo. Additional features for compatible phones include: Bluetooth audio streaming for 2 active devices, voice command pass-through to phone, Apple CarPlay and Android Auto capable. (STD)
- Audio system feature, 6-speaker system (Requires Crew Cab or Double Cab model.)
- Bluetooth for phone, connectivity to vehicle infotainment system

Interior

- Seats, front 40/20/40 split-bench (STD)
- Seat trim, Vinyl
- Seat adjuster, driver 4-way manual
- Seat adjuster, passenger 4-way manual
- Seat, rear 60/40 folding bench (folds up), 3-passenger (includes child seat top tether anchor) (Requires Crew Cab or Double Cab model.)
- Floor covering, rubberized-vinyl (Not available with LPO floor liners.)
- Steering wheel, urethane
- Steering column, Tilt-Wheel, manual with wheel locking security feature
- Instrument cluster, 6-gauge cluster featuring speedometer, fuel level, engine temperature, tachometer, voltage and oil pressure
- Driver Information Center, 3.5" diagonal monochromatic display
- Exterior Temperature Display located in radio display

This document contains information considered Confidential between GM and its Clients uniquely. The information provided is not intended for public disclosure. Prices, specifications, and availability are subject to change without notice, and do not include certain fees, taxes and charges that may be required by law or vary by manufacturer or region. Performance figures are guidelines only, and actual performance may vary. Photos may not represent actual vehicles or exact configurations. Content based on report preparer's input is subject to the accuracy of the input provided.

Data Version: 10301. Data Updated: Feb 10, 2020 10:26:00 PM PST.



Wilson County Motors

Sabrina Edwards | 615-444-9642 | Sabrina@wilsoncountyauto.com

Vehicle: [Fleet] 2020 Chevrolet Silverado 1500 (CK10743) 4WD Crew Cab 157" Work Truck ( Complete)

Interior

Rear Seat Reminder (Requires Crew Cab or Double Cab model.)
Window, power front, drivers express up/down (Standard on Crew Cab and Double Cab models.)
Window, power front, passenger express down (Standard on Crew Cab and Double Cab models.)
Windows, power rear, express down (Not available with Regular Cab models.)
Door locks, power (Standard on Crew Cab and Double Cab models.)
Power outlet, front auxiliary, 12-volt
USB port, located on instrument panel
Air conditioning, single-zone
Air vents, rear, heating/cooling (Not available on Regular Cab models.)
Mirror, inside rearview, manual tilt
Assist handles front A-pillar mounted for driver and passenger, rear B-pillar mounted

Safety-Mechanical

StabiliTrak, stability control system with Proactive Roll Avoidance and traction control, includes electronic trailer sway control and hill start assist

Safety-Exterior

Daytime Running Lamps with automatic exterior lamp control

Safety-Interior

Airbags, dual-stage frontal airbags for driver and front outboard passenger; Seat-mounted side-impact airbags for driver and front outboard passenger; Head-curtain airbags for front and rear outboard seating positions; Includes front outboard Passenger Sensing System for frontal outboard passenger airbag (Always use seat belts and child restraints. Children are safer when properly secured in a rear seat in the appropriate child restraint. See the Owner's Manual for more information.)

Rear Vision Camera

Teen Driver a configurable feature that lets you activate customizable vehicle settings associated with a key fob, to help encourage safe driving behavior. It can limit certain available vehicle features, and it prevents certain safety systems from being turned off. An in-vehicle report card gives you information on driving habits and helps you to continue to coach your new driver

Tire Pressure Monitoring System with Tire Fill Alert (does not apply to spare tire)

This document contains information considered Confidential between GM and its Clients uniquely. The information provided is not intended for public disclosure. Prices, specifications, and availability are subject to change without notice, and do not include certain fees, taxes and charges that may be required by law or vary by manufacturer or region. Performance figures are guidelines only, and actual performance may vary. Photos may not represent actual vehicles or exact configurations. Content based on report preparer's input is subject to the accuracy of the input provided.

Data Version: 10301. Data Updated: Feb 10, 2020 10:26:00 PM PST.



Wilson County Motors

Sabrina Edwards | 615-444-9642 | Sabrina@wilsoncountyauto.com

Vehicle: [Fleet] 2020 Chevrolet Silverado 1500 (CK10743) 4WD Crew Cab 157" Work Truck (✔ Complete)

WARRANTY

Warranty Note: <<< Preliminary 2020 Warranty Note >>>

Basic Years: 3

Basic Miles/km: 36,000

Drivetrain Years: 5

Drivetrain Miles/km: 60,000

Drivetrain Note: HD Duramax Diesel: 5 Years/100,000 Miles; Qualified Fleet Purchases: 5 Years/100,000 Miles

Corrosion Years (Rust-Through): 6

Corrosion Years: 3

Corrosion Miles/km (Rust-Through): 100,000

Corrosion Miles/km: 36,000

Roadside Assistance Years: 5

Roadside Assistance Miles/km: 60,000

Roadside Assistance Note: HD Duramax Diesel: 5 Years/100,000 Miles; Qualified Fleet Purchases: 5 Years/100,000 Miles

Maintenance Note: 1 Year/1 Visit

This document contains information considered Confidential between GM and its Clients uniquely. The information provided is not intended for public disclosure. Prices, specifications, and availability are subject to change without notice, and do not include certain fees, taxes and charges that may be required by law or vary by manufacturer or region. Performance figures are guidelines only, and actual performance may vary. Photos may not represent actual vehicles or exact configurations. Content based on report preparer's input is subject to the accuracy of the input provided.

Data Version: 10301. Data Updated: Feb 10, 2020 10:26:00 PM PST.



Wilson County Motors

Sabrina Edwards | 615-444-9642 | Sabrina@wilsoncountyauto.com

Vehicle: [Fleet] 2020 Chevrolet Silverado 1500 (CK10743) 4WD Crew Cab 157" Work Truck (✔ Complete)



Note:Photo may not represent exact vehicle or selected equipment.

This document contains information considered Confidential between GM and its Clients uniquely. The information provided is not intended for public disclosure. Prices, specifications, and availability are subject to change without notice, and do not include certain fees, taxes and charges that may be required by law or vary by manufacturer or region. Performance figures are guidelines only, and actual performance may vary. Photos may not represent actual vehicles or exact configurations. Content based on report preparer's input is subject to the accuracy of the input provided.

Data Version: 10301. Data Updated: Feb 10, 2020 10:26:00 PM PST.

FT-24-2 LP

Deckover Tags Low Pro

GVWR LBS:	GAWR LBS:	WEIGHT LBS:	CAPACITY LBS:
30,500	24,000	6,800	23,700

- Engineered, Cambered, Fabricated, 14" Main Beams
- 4" pierced High Tensile Jr I-Beam crossmembers 16" o center
- 7" Channel side rails, flat side out
- Tread Plate covered wheels
- * NOTE: Dealer must add 12% FET on retail price. Tax is to be calculated & remitted by dealer.

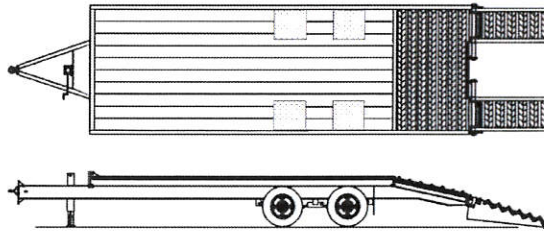

Standard & Other Options	Description	Std. Option	Std. Qty.	Unit
Deck Length	Main Deck Length (Pierced Frame)	X	20.00	Feet
Beavertail	Self Cleaning 5" x 3" Angle Iron Beavertail	X	5.00	Feet
Deck Type	White Oak 2" Nom	X	1.00	Std
Ramps; Rear	5' x 20" Self Cleaning 5" X 3" Angle Iron Spring Assist	X	1.00	Pair
Appx Deck Height	33" Loaded, 35" Unloaded	X	1.00	Inches
Width	102" OD	X	1.00	Inches
Tie Downs	D-Rings, 1" ** Straight ** (One Set Centered on BVT)	X	10.00	Each
Brakes	Electric, Dexter FSA (Fwd Self Adj) On All Axles	X	1.00	Std
Axles	12K Dexter Oil Bath	X	2.00	Std
Suspension	Dexter Spring	X	1.00	Std
Tires & Wheels	ST235/80R 16 E, 8 Bolt [16 x 6] Hub Pilot	X	8.00	Std
Hitch Length	Center of Coupler to Headboard, Appx	X	5.30	Feet
Hitch Type	3" Adjustable Lunette Eye/Pintle, [C] 66,000 lb Plate Mount (3/4" Bolt)	X	1.00	Std
Jack	12K Drop Leg ** Side Wind **	X	1.00	Std
Plug	7 Pole RV	X	1.00	Std
Lights	LED Lights (Peterson), Sealed Wiring Harness (Sealco)	X	1.00	Std
Trailer Color	Felling Black # CCA945378 (White Felling Decal)	X	1.00	Std
Stripe Color	White	X	1.00	Std
Standard	1/2" Safety Chains, Grade 70	X	1.00	Std
Standard	2 Steps, 1 on the Standard Hitch and 1 in front of Axles on Roadside	X	2.00	Std
Standard	Document Holder	X	1.00	Std
Standard	Tool Box, with Lockable Cover	X	1.00	Std
GVWR	30,500 lbs	X	1.00	Std